

# *Installation Manual*

## **INMARSAT FLEETBROADBAND**

### *Model FELCOM250/FELCOM500*

---

<b>SAFETY INSTRUCTIONS .....</b>	<b>i</b>
<b>SYSTEM CONFIGURATION .....</b>	<b>ii</b>
<b>EQUIPMENT LISTS.....</b>	<b>iii</b>
<b>1. HOW TO INSTALL THE UNIT.....</b>	<b>1-1</b>
1.1 Antenna Unit .....	1-1
1.2 Communication Unit.....	1-11
1.3 IP Handset .....	1-12
1.4 Incoming Indicator (option) .....	1-13
1.5 Telephone (Option).....	1-14
1.6 Facsimile FAX-2840 (Option).....	1-18
1.7 Incoming bell (Option).....	1-19
<b>2. CONNECTIONS.....</b>	<b>2-1</b>
2.1 Standard Connection .....	2-1
2.2 Antenna Cable .....	2-2
2.3 Communication Unit.....	2-5
2.4 Notice for network connection.....	2-7
2.5 Desktop Installation of Communication Unit to comply with IPX2 (dripping) standard .....	2-8
2.6 LAN Cable Fabrication.....	2-10
<b>3. SETTING AFTER INSTALLATION .....</b>	<b>3-1</b>
3.1 Preparation for Setting .....	3-1
3.2 GPS Setting .....	3-4
3.3 Analog Port Setting .....	3-5
3.4 Incoming Indicator Setting .....	3-7
3.5 Serial Port Setting .....	3-8
3.6 Satellite Setting .....	3-8
3.7 OTA Setting .....	3-9
3.8 Handset Setting .....	3-9
3.9 How to Copy and Move Contacts .....	3-13
3.10 User Registration (for data connection) .....	3-14
<b>APPENDIX 1 JIS CABLE GUIDE .....</b>	<b>AP-1</b>
<b>PACKING LIST .....</b>	<b>A-1</b>
<b>OUTLINE DRAWINGS .....</b>	<b>D-1</b>
<b>INTERCONNECTION DIAGRAM .....</b>	<b>S-1</b>

**ECF**

(Elemental Chlorine Free)

The paper used in this manual  
is elemental chlorine free.

**FURUNO ELECTRIC CO., LTD.**

9-52 Ashihara-cho,  
Nishinomiya, 662-8580, JAPAN

• FURUNO Authorized Distributor/Dealer

All rights reserved. Printed in Japan

Pub. No. IME-56660-W

(AKMU ) FELCOM500/250

A : AUG. 2009

W : DEC. 06, 2017







0 0 0 1 9 4 9 1 8 1 0



# SAFETY INSTRUCTIONS

Read these safety instructions before you operate the equipment.

 <b>WARNING</b>	Indicates a condition that can cause death or serious injury if not avoided.
 <b>CAUTION</b>	Indicates a condition that can cause minor or moderate injury if not avoided.

 Warning, Caution	 Prohibitive Action	 Mandatory Action
--	--	--

**WARNING**

 **Do not open the equipment unless totally familiar with electrical circuits and service manual.**

Only qualified personnel should work inside the equipment.

 **Do not approach the radome closer than 1.4 m (FELCOM 500) or 0.7 m (FELCOM 250) when it is transmitting.**

The radome emits radio waves which can be harmful to the human body, particularly the eyes.

RF power density on antenna aperture	FELCOM500 distance	FELCOM250 distance
100W/m <sup>2</sup>	-	-
25W/m <sup>2</sup>	0.5 m	0.4 m
10W/m <sup>2</sup>	1.4 m	0.7 m

 **Turn off the power at the mains switchboard before beginning the installation. Post a sign near the switch to indicate it should not be turned on while the equipment is being installed.**

Fire, electrical shock or serious injury can result if the power is left on or is applied while the equipment is being installed.

**WARNING**

 **Ground the equipment to prevent electrical shock and mutual interference.**

 **Confirm that the power supply voltage is compatible with the voltage rating of the equipment.**

Connection to the wrong power supply can cause fire or damage the equipment.

 **Keep the following compass safe distances to prevent interference to a magnetic compass.**

Unit	Standard Compass	Steering Compass
FELCOM 500 Antenna Unit	0.75 m 0.70 m (XL spec.*)	0.40 m 0.35 m (XL spec.*)
FELCOM 250 Antenna Unit	0.70 m 0.75 m (XL spec.*)	0.40 m 0.45 m (XL spec.*)
Communication Unit	0.40 m 0.50 m (XL spec.*)	0.30 m 0.30 m (XL spec.*)
IP Handset	0.70 m	0.45 m
Facsimile (FAX-2840)	1.50 m	0.95 m
Telephone	0.80 m	0.55 m
Incoming Indicator	0.45 m	0.30 m
Incoming bell	0.45 m	0.30 m
AC-DC Power Supply	0.90 m	0.60 m

\*: "XL" is mentioned in the nameplate.

# SYSTEM CONFIGURATION

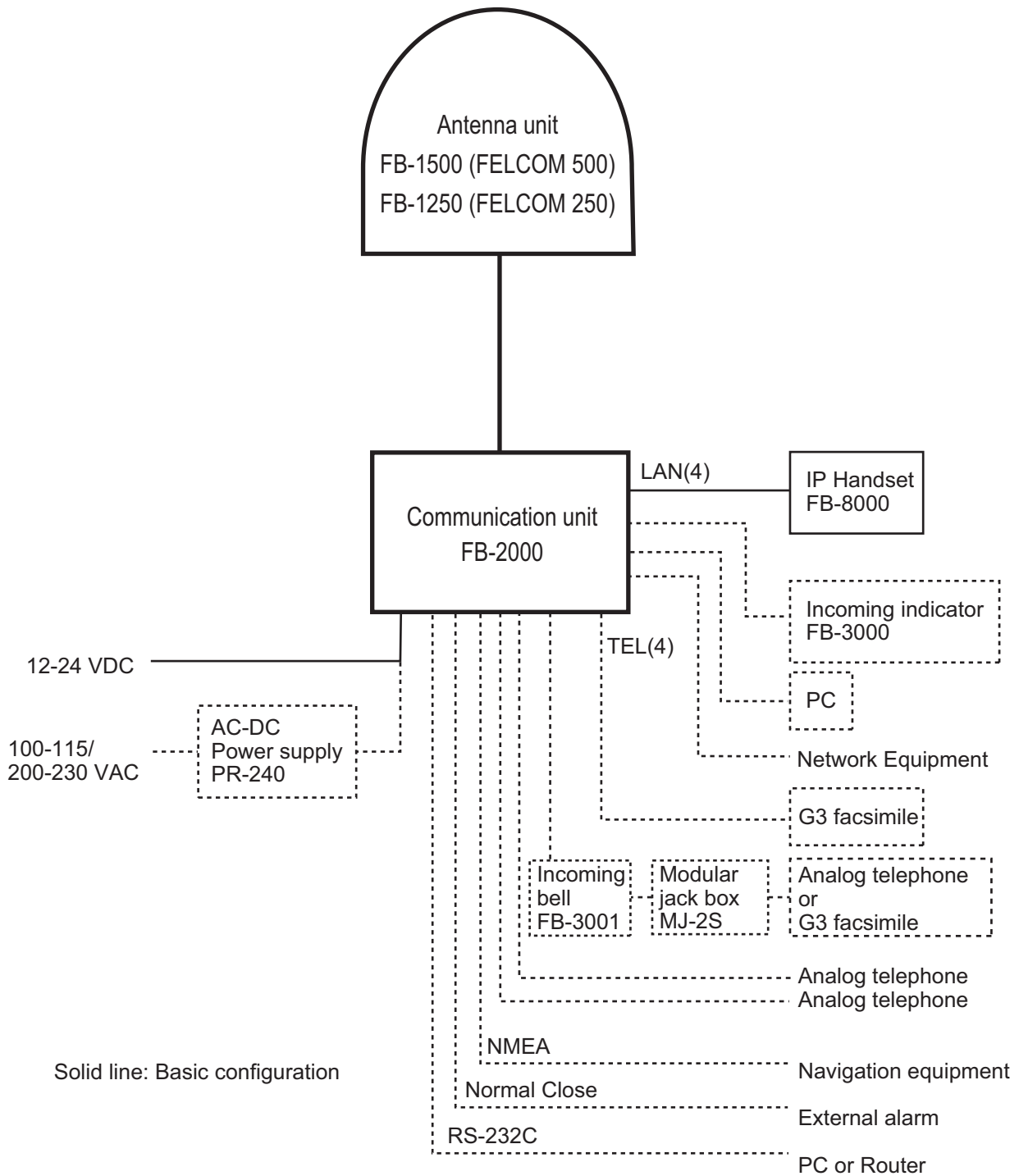

## Environmental Category

Antenna unit	To be installed in an exposed area
Communication unit, IP handset, Incoming indicator, Incoming bell	To be installed in a protected area

# EQUIPMENT LISTS

## Standard Supply

Name	Type	Code No.	Qty	Remarks
Antenna unit	FB-1500-A	-	1	For FELCOM 500, w/attachment
	FB-1500-C	-		For FELCOM 500, XL spec., w/attachment
	FB-1250-A	-		For FELCOM 250, w/attachment
	FB-1250-C	-		For FELCOM 250, XL spec., w/attachment
	FB-1250-B	-		For FELCOM 250, no attachment
	FB-1250-D	-		For FELCOM 250, XL spec., no attachment
Communication Unit	FB-2000	-	1	
IP handset	FB-8000	-	1	
Installation materials*	CP16-04100	000-015-746	1	30 m antenna cable
	CP16-04110	000-015-747		50 m antenna cable
	CP16-04120	000-015-865		40 m antenna cable
	CP16-04401	001-077-180	1	For FB-1500-A/C
	CP16-04502	001-148-980		For FB-1250-A/C
	CP16-04401/04402	001-067-780		For FB-1500
	CP16-04501/04502	001-086-500		For FB-1250
	CP16-03810	000-015-759	1	For FB-2000
CP16-03901	001-067-350	1	For FB-8000	
Spare parts	SP16-01901	001-067-320	1	Fuses for FB-2000

\*: See lists at the back of this manual.

## Optional Supply

Name	Type	Code No.	Remarks
Incoming indicator	FB-3000	000-015-763	w/CP16-04001
Telephone Set	GEMINI 9333B4	000-033-325	Telephone and Fixing base set
	GEMINI 9333B4 Tilting Type	000-035-109	
Phone Fixing Base Set	GEMINI9333	000-034-207	Only Fixing base set
	GEMINI9333 Tilting Type	000-035-108	
Facsimile	FAX-2840	000-024-872	w/CP16-06010
Transformer	OP16-70	001-196-750	Transformer PAL-1000UE +cable for FAX-2840
Drum unit	DR2200	001-258-440	For FAX-2840
Toner cartridge	TN2210	001-258-460	For FAX-2840
AC-DC power supply	PR-240	000-013-632	
IP handset	FB-8000	000-015-768	
Coaxial cable	12D-SFA-LITE-CV	001-235-960	100 m for antenna cable

## EQUIPMENT LISTS

Name	Type	Code No.	Remarks
Installation materials	CP16-04121	001-067-300	Connector N-SP-12DSFA-CF for cable 12D-SFA-LITE-CV
	CP16-04131	001-067-310	Connector N-P-18U-CF (2 pcs) for RG-18
Connector	CP03-28901	008-542-460	Modular connector MPS588-C2 pcs for LAN cable
LAN cable	MOD-Z072-020+	001-167-880-10	2 m, modular plug for both ends
	MOD-Z072-050+	001-167-890-10	5 m, modular plug for both ends
	MOD-Z072-100+	001-167-900-10	10 m, modular plug for both ends
	FR-FTPC-CY *10m*	001-240-510	10 m with armor, no plug
	FR-FTPC-CY *20m*	001-240-520	20 m with armor, no plug
	FR-FTPC-CY *30m*	001-240-530	30 m with armor, no plug
	FR-FTPC-CY *50m*	001-240-540	50 m with armor, no plug
	FR-FTPC-CY *100m*	001-240-550	100 m with armor, no plug
Modular jack set	OP16-13	000-043-228	MJ-2S, 3 m cord, lug
Modular jack box	OP16-8	000-043-272	MJ-2S, lug
Joint box	TL-CAT-012	000-167-140-10	Fro LAN cable extension
Cable assy.	81-521-1204-010	001-073-240-10	5 m cable w/ D-sub 9 pin connector at both ends
Incoming bell	FB-3001	-	For analog TEL. w/CP16-06401
Splash proof cap	16-023-5501	001-493-320	For FB-3001
Modular jack box	OP16-10	000-043-278	Box type
	OP16-11	000-043-279	Flush mount type
Pole mount kit	OP16-52	000-017-061	For FELCOM 250 antenna unit
Kit for RF interference	OP16-50	000-016-316	For FELCOM 500
Radiation sticker	OP16-53	001-115-470-10	For FELCOM 500
Lifting tool for antenna	OP16-55	001-121-170	For FELCOM 500 antenna unit
FX mode setup (Instructions)	C52-01602-*	000-192-742-1*	English/Japanese

This product includes software to be licensed under the GNU General Public License (GPL), GNU Lesser General Public License (LGPL), BSD, Apache, MIT and others.  
The program(s) is/are free software(s), and you can copy it and/or redistribute it and/or modify it under the terms of the GPL or LGPL as published by the Free Software Foundation. Please access to the following URL if you need source codes.  
[https://www.furuno.co.jp/contact/cnt\\_oss.html](https://www.furuno.co.jp/contact/cnt_oss.html)

This product uses the software module that was developed by the Independent JPEG Group.

France Telecom - TDF - Groupe des Ecoles des Telecommunications Turbo codes patents license.

Windows Media is a registered trademark or trademark of Microsoft Corporation in the United States and/or other countries.

Quick Time is a trademark of Apple Inc.

Real Player is a registered trademark or trademark of RealNetworks, Inc.

# 1. HOW TO INSTALL THE UNIT

---

## NOTICE

Do not apply paint, anti-corrosive sealant or contact spray to coating or plastic parts of the equipment.

Those items contain organic solvents that can damage coating and plastic parts, especially plastic connectors.

## 1.1 Antenna Unit

### General

Interfering objects (especially metal objects like masts) near the antenna can, in the worst case, prevent reception or transmission. Further, RF radiation from the antenna will affect the human body. Keep these and the following guidelines in mind when selecting a mounting location for the antenna unit.

### Secure unobstructed path in all directions

The best mounting location secures an unobstructed path between the antenna unit and the satellites, from horizontal to zenith. In other words, whatever the direction the antenna unit is pointing there are no interfering objects within the main beam (22° for FELCOM 500, 40° for FELCOM 250). While this might be feasible on some vessels, on others it is impossible due to space considerations. Locate the antenna unit at least three meters away from masts having a diameter more than 15 centimeters.

### Select a location low in vibration

The maximum permissible vibration amplitude in three axis direction should be as shown in the table below. Consult with the shipyard to determine the mounting location which meets the requirements shown in the table.

Freq. Range	Max. Amplitude
4 to 10 Hz	2.54 mm (max. 9.8 m/s <sup>2</sup> )
10 to 15 Hz	0.76 mm (max. 6.86 m/s <sup>2</sup> )
15 to 25 Hz	0.40 mm (max. 9.8 m/s <sup>2</sup> )
25 to 33 Hz	0.23 mm (max. 9.8 m/s <sup>2</sup> )

## 1. HOW TO INSTALL THE UNIT

### **Locate away from passengers and crew**

Radio waves can be harmful to the human body. Because safe distances change by country and ship construction, there is no standard formula to calculate safe distance. However, below are general guidelines.

- FELCOM 500: Personnel should not approach an area in which the radiation level is higher than  $10 \text{ W/m}^2$ , i.e., within 1.40 m from the radome surface.

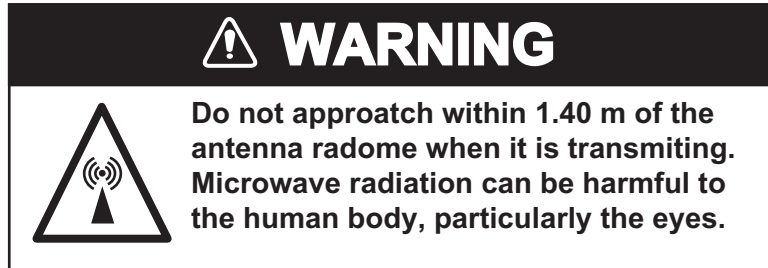

To alert personnel not to approach the antenna unit, attach the caution labels (supplied as installation materials) to any bulkhead which is at the position of 1.40 m from the antenna unit.

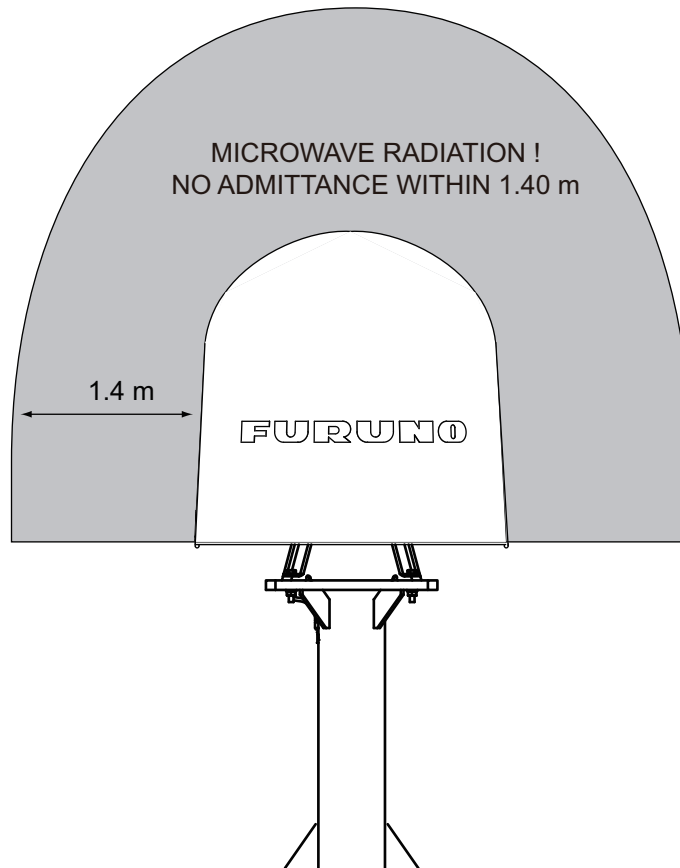



- FELCOM 250: Personnel should not approach an area in which the radiation level is higher than  $10 \text{ W/m}^2$ , i.e., within 0.70 m from the radome surface.

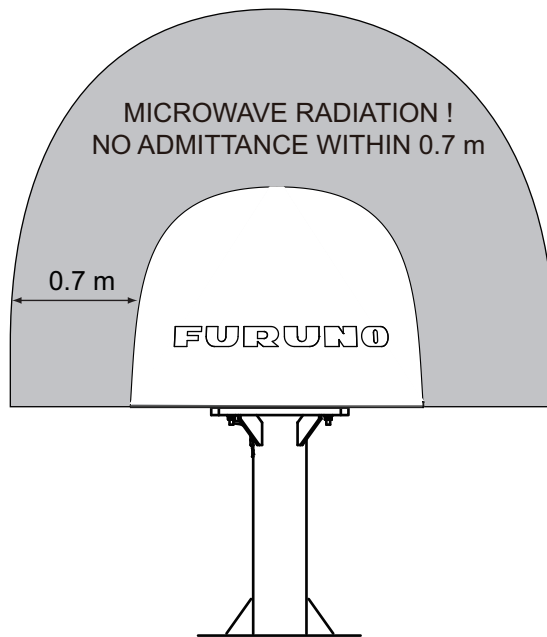

To alert personnel not to approach the antenna unit, attach the radiation warning sticker (supplied as installation materials) to any bulkhead which is at the position of 0.70 m from the antenna unit.

**Minimum distance from other antennas**

MF/HF antennas, communication/navigation antennas:

The antenna unit should be at least five meters from a MF/HF antenna. The VHF, satellite navigation antenna and other communication antennas should be at least four meters away.

Radar:

The antenna unit should be at least 5 meters away to protect the low-noise amplifier in the FELCOM 500/FELCOM 250 antenna unit. If this distance cannot be secured be sure the antenna unit is not within the radar beam. However, never install the antenna unit within 3 m of a radar antenna.

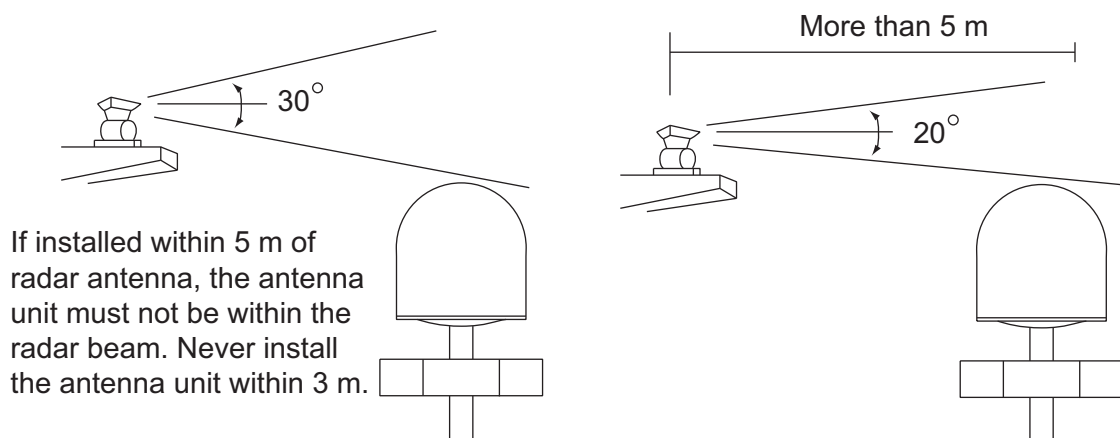

**Compass safe distance**

Locating the antenna unit too close to a compass can affect the compass performance. Keep the compass safe distance to prevent interference to the magnetic compass. See page i.

1. HOW TO INSTALL THE UNIT

**Other mounting guidelines**

Other important mounting guidelines are

- Locate the antenna unit away from exhaust stacks (foreign material on the radome can interfere with reception and transmission).
- Keep the unit away from heat sources.
- Locate the unit away from places where fuels and chemical solvents are stored.
- Keep in mind the length of the cable from the Communication Unit is maximum 100 meters (when coaxial cable 12D-SFA-LITE-CV is used).

**Guardrail, platform**

To facilitate servicing, construct a mast of about one meter (40") in height. (See page 1-5.) The paragraphs which follow provide guidelines for selection and construction of the mast.

Fit the mast with a guardrail and platform (or steps), for serviceman's safety. (In most installations the serviceman stands on the platform while checking the radome. Thus this distance should be secured for ease of servicing.) The height of the guardrail should be as tall as possible to ensure safety.

**Mast strength**

The mast material must be sufficiently strong to meet the demands of the marine environment. It should satisfy the following requirements.

- It must be able to support radome mass plus at least 2.5 cm (1") of ice and snow. Special consideration should be given if the unit is operated in areas of heavy snow or freezing temperature.
- The mast bending moment must be able to withstand expected maximum pitching, rolling and wind pressure.
- To prevent resonance at low frequencies (approximately 5 Hz), four stays can be fixed between the mast and the mounting base.

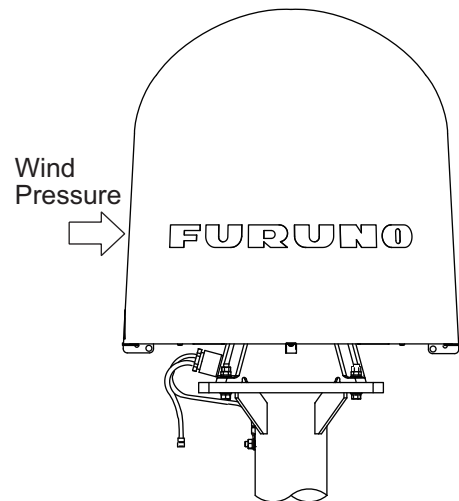

(Above figure: FELCOM 500)

Item	FELCOM 250			
	FB-1250-A	FB-1250-C	FB-1250-B	FB-1250-D
Antenna unit mass	9.5 kg (20.8 lb) ± 10%	8.6 kg (18.8 lb) ± 10%	6.6 kg (14.6 lb) ± 10%	5.7 kg (12.5 lb) ± 10%
Maximum wind pressure (at wind speed 56 m/s)	36.3 N			

Item	FELCOM 500	
	FB-1500-A	FB-1500-C
Antenna unit mass	21 kg (46 lb) ± 10%	22 kg (48.2 lb) ± 10%
Maximum wind pressure (at wind speed 56 m/s)	280 N	

**Antenna mast and mounting base**

To get the best performance from the antenna electronics and mechanics, the antenna must be installed properly on a specially designed mast with suitable flange and rubber gasket. Below are guidelines for installation of the mounting mast and mounting base.

- The mounting base should be parallel to the ship's waterline (tolerance:  $\pm 3^\circ$ ).
- Weld a ground bolt of stainless steel to the mast (figure below). Connect the ground wire from the antenna unit to the ground bolt.

FELCOM 500 (FB-1500-A/C) FELCOM 250 (FB-1250-A/C)	FELCOM 250 (FB-1250-B/D)				
<p style="text-align: center;">[Mounting base]</p>	<p style="text-align: center;">[Mounting base]</p>				
<p>Thickness</p> <table border="1" style="margin-left: auto; margin-right: auto; border-collapse: collapse;"> <thead> <tr> <th style="padding: 5px;">FELCOM 500</th> <th style="padding: 5px;">FELCOM 250</th> </tr> </thead> <tbody> <tr> <td style="padding: 5px;">Minimum 20 mm (0.79")</td> <td style="padding: 5px;">Minimum 10 mm (0.39")</td> </tr> </tbody> </table>		FELCOM 500	FELCOM 250	Minimum 20 mm (0.79")	Minimum 10 mm (0.39")
FELCOM 500	FELCOM 250				
Minimum 20 mm (0.79")	Minimum 10 mm (0.39")				
<p style="text-align: center;">[Antenna mast: Example]</p>	<p style="text-align: center;">[Antenna pole: Example]</p>				

# 1. HOW TO INSTALL THE UNIT

## **FB-1500-A/C / FB-1250-A/C: How to install the antenna unit**

Carefully unpack the radome and check for damage.

For FB-1500-A/C, the optional kit OP16-55 is necessary to lift the antenna unit.

Lifting tool for antenna: Type OP16-55, Code number 001-121-170

Name	Type	Code no.	Qty
Shackle	JISB2801	000-174-468-10	4
Lifting tool for antenna	16-021-5508-1	100-362-721-10	1

### **Procedure**

1. For the FB-1500-A/C, do the following:
  - 1) Loosen four lifting lugs and turn them to outside at the bottom of the radome as shown in the figure below.
  - 2) Then tighten four bolts for lifting lugs firmly. If not tightened, the bolt may loosen, causing the antenna unit to fall, when hoisting the antenna unit.
  - 3) Arrange shackle, lifting tool for antenna and lifting lug as shown below.
  - 4) Cover the part of the radome which contacts the lifting tool for antenna with protective material (rubber mat, etc.), to prevent damage to the radome when hoisting it to the mounting location.
  - 5) Lift the antenna unit to the mounting location.

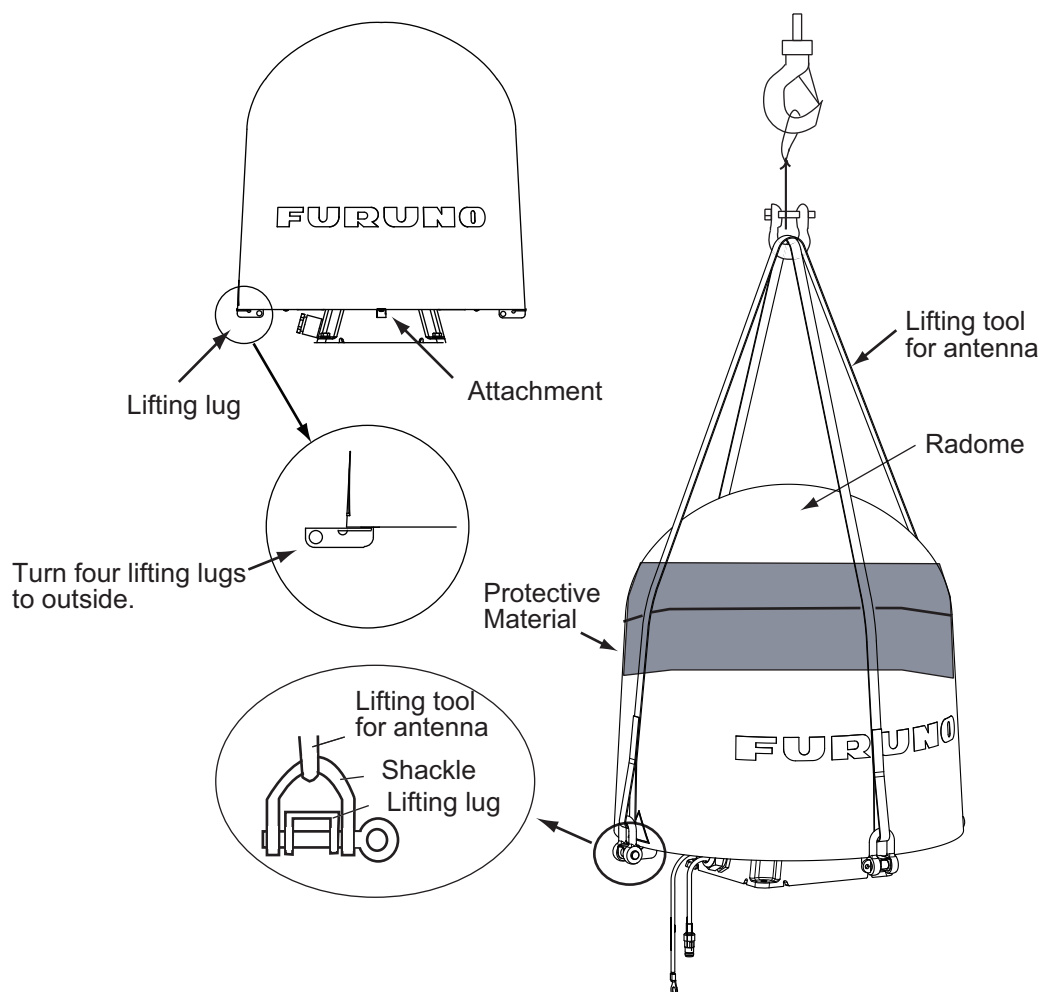

*For FB-1500-A/C only*

## 1. HOW TO INSTALL THE UNIT

2. Lay the rubber mat on the mounting base and put the antenna unit on the rubber mat, keeping in mind cable gland direction (standard direction is stern).
3. Fix the antenna unit with four sets of hexagonal bolts and nuts as shown below.  
**Note:** Tighten first nut with torque 36.5 Nm, then tighten second nut with the same torque.
4. Connect the ground wire to the ground bolt.
5. For FB-1250-A/C, attach the radiation warning sticker (small) to the bow and stern sides of the antenna radome. If these locations are not suitable, attach the radiation warning sticker (big) to the ship's body near the antenna radome.
6. Coat all bolts and nuts with silicone sealant to prevent electrolytic corrosion.
7. For FB-1500-A/C, restore the lifting lugs to their original positions.

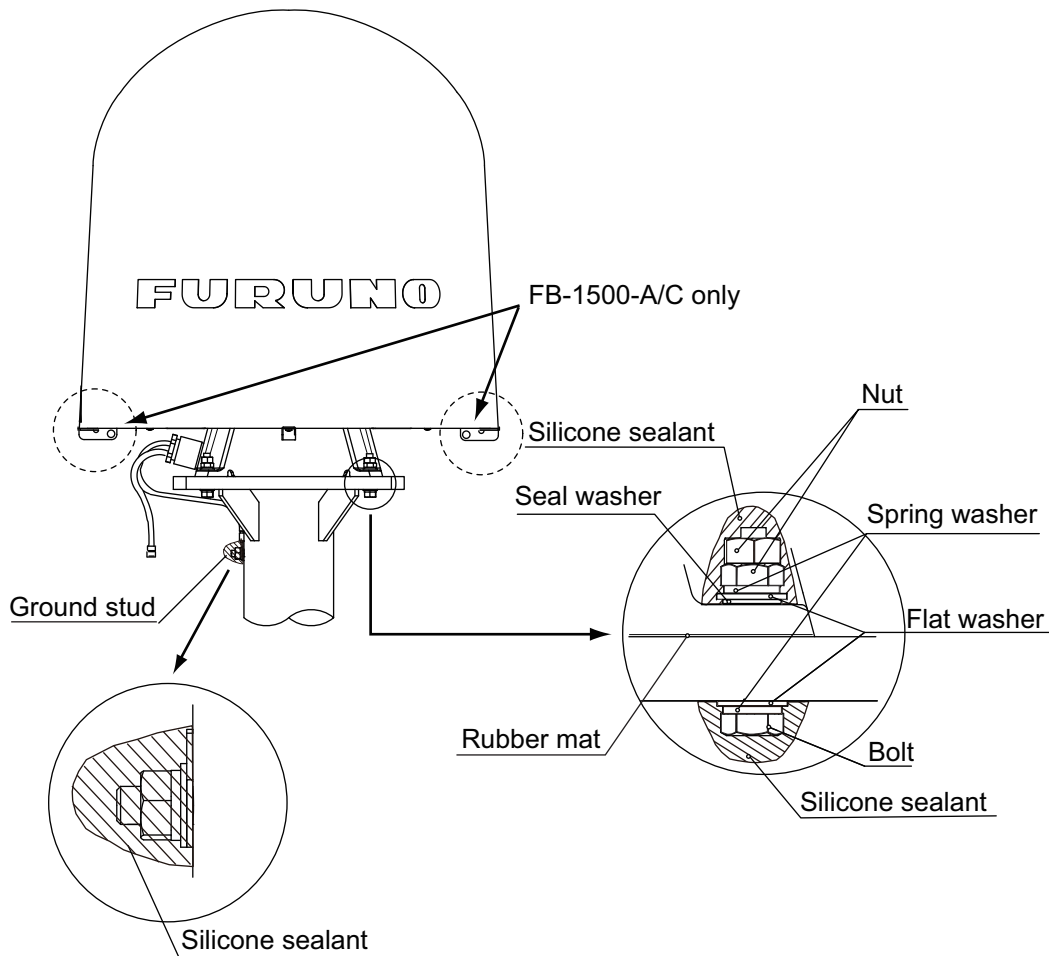

## 1. HOW TO INSTALL THE UNIT

### **FB-1250-B/D: How to install the antenna unit**

Carefully unpack the radome and check for damage. Run the antenna cable before installation of the antenna unit.

#### **Procedure**

1. If the rubber mat is not attached at the bottom of the dome, peel off the tape from the rubber mat and attach the rubber mat at the bottom of the dome. If another rubber mat is supplied, attach it to the antenna mounting base.
2. Connect the antenna cable to the coaxial plug on the bottom of the antenna unit.
3. Wrap the self-adhesive tape all around the coaxial connector for waterproofing and wrap the vinyl tape on the self-adhesive tape.

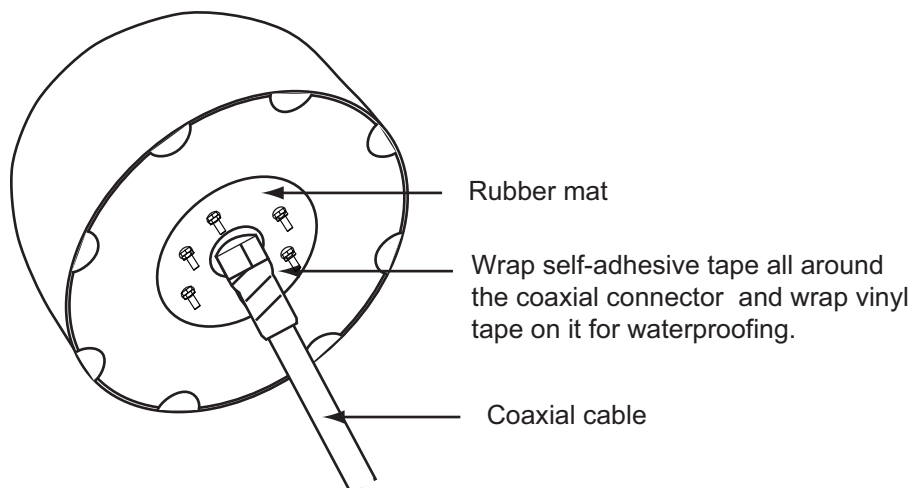

Antenna unit bottom

4. Put the antenna unit on the mounting base.  
The antenna unit is free of direction. However, preferably install the antenna unit, so the FURUNO logos face the port/ starboard side.
5. Fasten the ground wire (supplied) to the antenna bolt near the ground stud on the antenna mast and secure with hexagonal nut, spring washer and flat washer.
6. Secure other antenna bolts with a set of hexagonal nuts, spring washers and flat washers as shown below on the next page.  
**Note:** To fix the antenna bolt, tighten first nut with torque 7.65 Nm and then tighten the second nut with the same torque.
7. Connect the ground wire to the ground stud on the antenna mast.
8. Attach the radiation warning sticker (small) to the bow and stern sides of the antenna radome. If these locations are not suitable, attach the radiation warning sticker (big) to the ship's body near the antenna radome.

9. Coat all bolts and nuts with silicone sealant to prevent electrolytic corrosion as shown below.

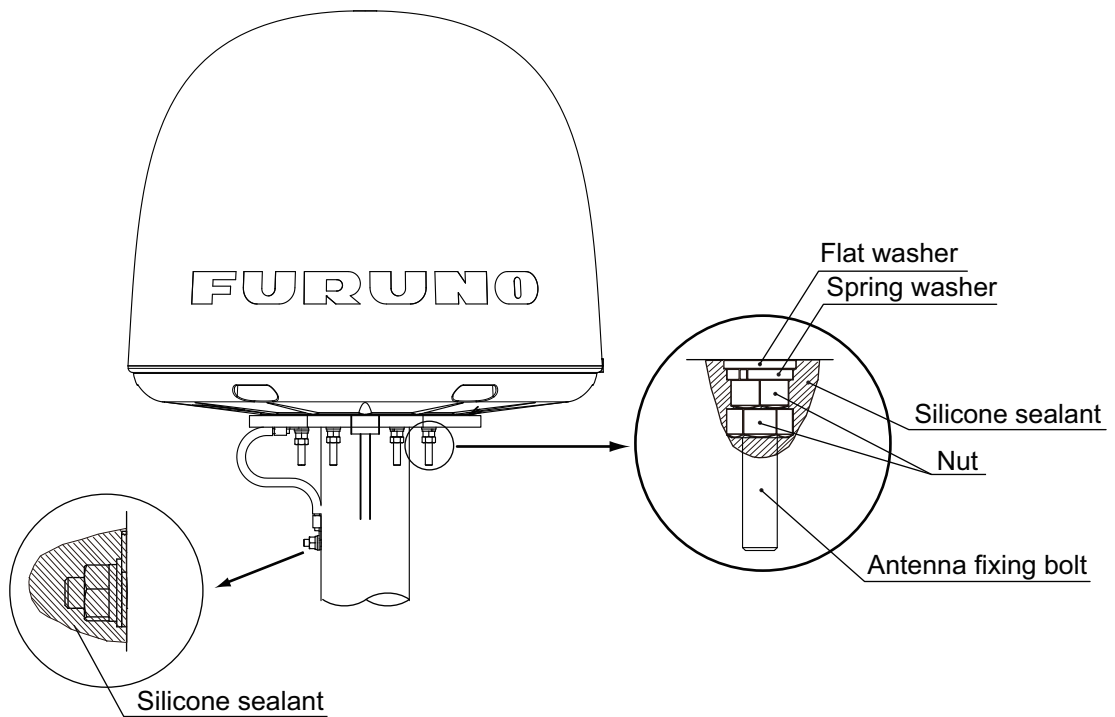

**Note:** The cable entry hole ( $\phi 60$ ) at the bottom of the antenna functions as ventilation hole, allowing trapped moisture to escape the dome. For that reason, ensure the hole is not blocked.

**How to mount the FELCOM 250 antenna unit with optional pole mount kit**

**Note:** The bottom caps (included in the optional pole mount kit) must be fitted. The caps prevent water leaking into the antenna unit.

*Pole Mount Kit (Type: OP16-52, Code: 000-017-061)*

Name	Type	Code no.	Qty
Mounting pole	SP-SAC-1031	000-173-963-10	1
Fixing plate	SP-SAC-1032	000-173-964-10	1

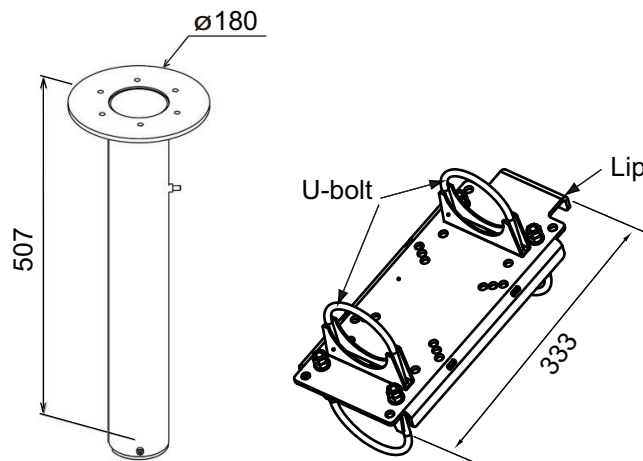

## 1. HOW TO INSTALL THE UNIT

1. Ask the shipyard to prepare and mount an antenna mast (diameter  $\phi 89$ : 80A).
2. Attach the fixing plate SP-SAC-1032 to the antenna mast by hanging the lip of the fixing plate on the top of the antenna mast.
3. Insert the mounting pole SP-SAC-1031 through the U-bolts of the fixing plate and fasten the U-bolts.
4. Put the FELCOM 250 antenna unit (FB-1250-B/D) on the mounting pole and fix it with nuts (see previous page).

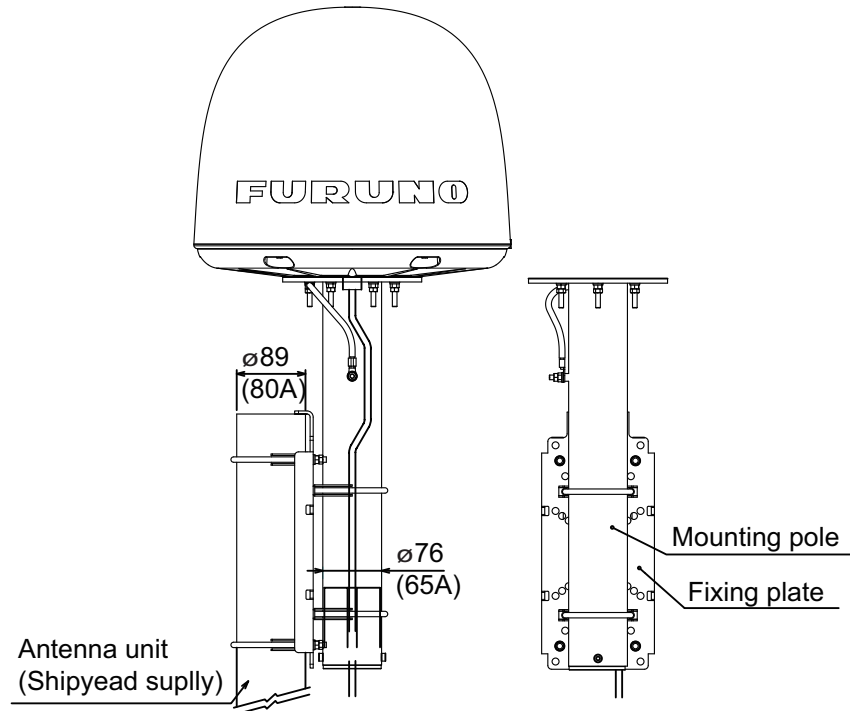



## 1.2 Communication Unit

Select a location for the Communication Unit (CU) by following the guidelines shown below.

- The unit is not waterproof. Keep the unit away from water splash.
- Keep the unit away from direct sunlight.
- The temperature and humidity must meet the requirements shown in the equipment specifications.
- Set the unit away from the exhaust pipes and vents.
- The installation location must have enough cool air.
- Install the unit where shock and vibration meet the requirements shown in the equipment specifications.
- Keep the unit away from the equipment that creates an electromagnetic field, for example, motor and generator.
- For maintenance and checking, leave enough space at the sides and rear of the unit. Refer to the outline drawing and provide some additional length in cables.
- Follow the recommended compass safe distances shown on page i to prevent the interference to a magnetic compass.

### How to install the CU

Follow the procedure shown below to install the CU on a desktop. See the outline drawing on page D-4 for details.

1. Place the template (supplied) of the CU on the installation site.
2. Mark the points for four pilot holes and makes the pilot holes for 5x50 self-tapping screws.
3. Put the unit on the installation site and fix it with four 5x50 self-tapping screws (supplied).

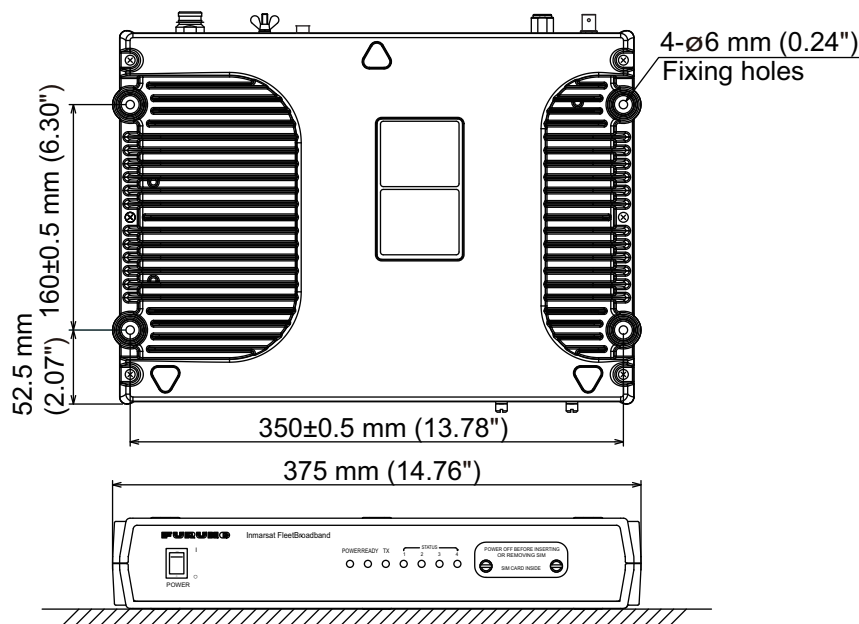

**Note:** It is necessary to install the Communication Unit on a desktop to comply with IPX2 (dripping) standard. Refer to section 2.5 for directions to how to install on a desktop.

## 1.3 IP Handset

The IP handset functions as a display and it may also be used for normal voice communication. The units (max 26 units) may be installed anywhere onboard the vessel. The IP handset is provided with a cradle. Fix the cradle to the bulkhead or installation panel. The cradle has two cable entries for convenience; bottom and rear.

1. To use the rear cable entry, make a hole of 18 mm (0.71") diameter in the installation site, Refer to the outline drawing.
2. Remove four screws from the cradle to separate the plastic case from the metal plate.
3. Fix the metal plate to the mounting site with four self-tapping screws.
4. Connect the LAN cable from the CU to the inner RJ45 port in the cradle.
5. If the bottom cable entry is used, run the LAN cable as shown in the figure below and fix it with a cable-tie.
6. Reattach the plastic cover.
7. Connect the cable from the handset to the outer RJ-45 port of the cradle.

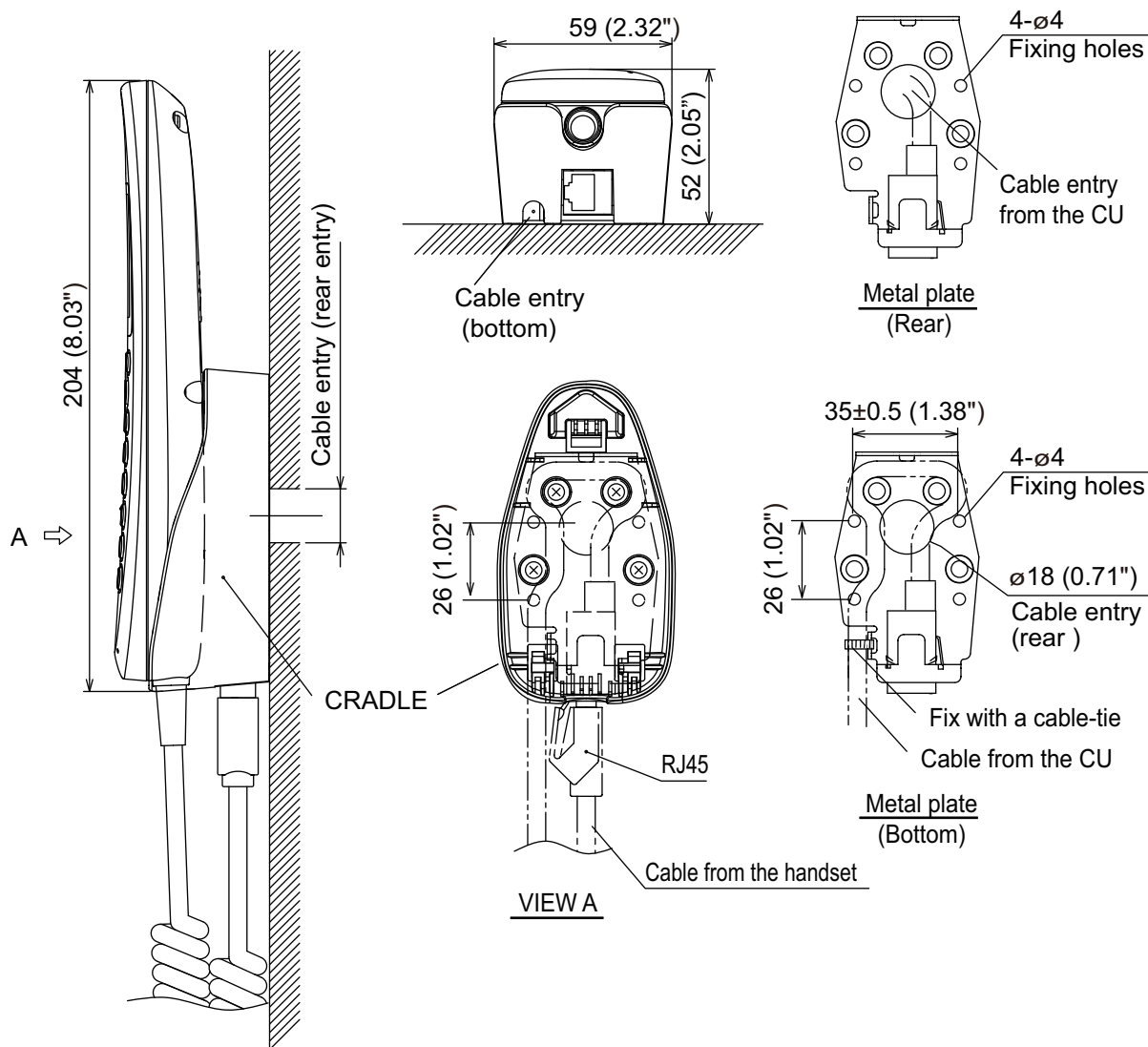

## 1.4 Incoming Indicator (option)

Select a location for the incoming indicator by following the information shown below.

- Keep the unit away from water splash.
- Keep the unit away from direct sunlight.
- Set the unit away from the exhaust pipes and vents.
- Follow the recommended compass safe distances shown on page i to prevent the interference to a magnetic compass.

### How to install on the bulkhead or bridge panel

1. Remove four screws from the unit to remove the lid.
2. Fix the case with four 4x16 self-tapping screws (supplied).
3. Reattach the lid with four screws.
4. Connect the cable from the CU.
5. Attach the cable fixture (supplied) with two screws.
6. Fasten the cable to the cable fixture with the cable tie (supplied).

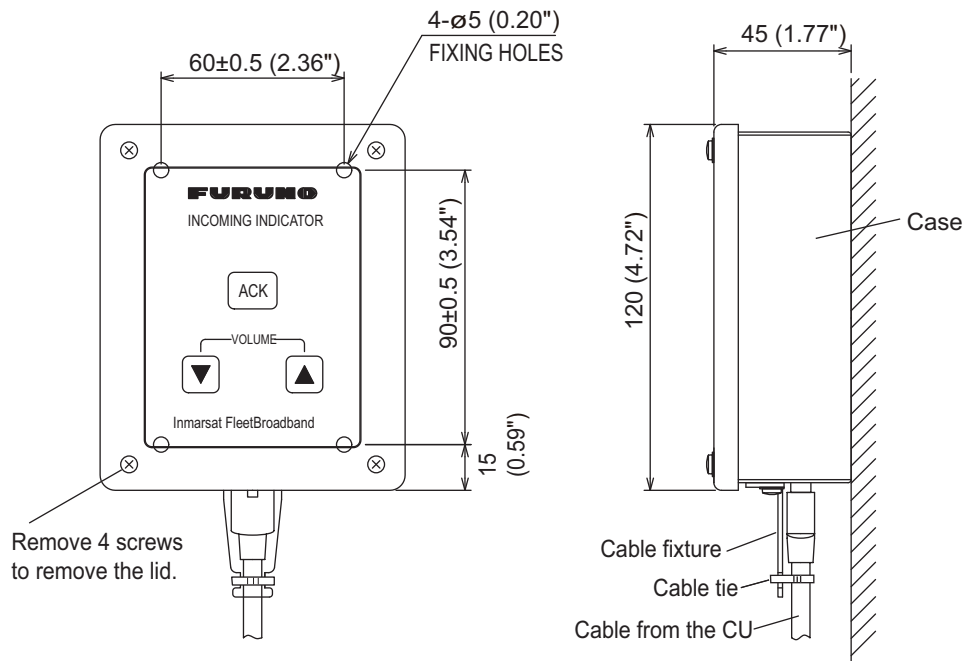

### How to install by the flush mount

1. Prepare a cutout in the installation location and make four pilot holes. Refer to the outline drawings.
2. Set the flush mount plate (supplied) to the cutout and fix it with four 4x16 self-tapping screws (supplied).
3. Remove four screws from the unit to remove the lid.
4. Fix the case with four M4x8 screws (supplied) to the flush mount plate.
5. Pass the cable from the CU through the bottom of the case.
6. Connect the cable to the port on the lid.
7. Attach the cable fixture (supplied) with two screws.
8. Fasten the cable to the cable fixture with the cable tie (supplied).

## 1. HOW TO INSTALL THE UNIT

9. Reattach the lid to the case with four screws.

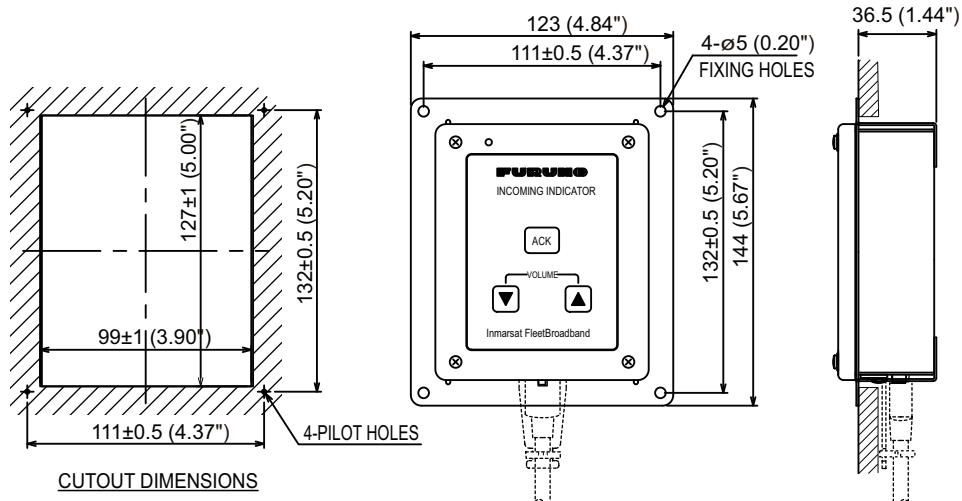

## 1.5 Telephone (Option)

Select a location for the Telephone GEMINI9333B4 with the fixing base by following the guidelines shown below. The fixing base has horizontal and tilted types.

- Keep the unit away from water splash.
  - Keep the unit away from direct sunlight.
  - Set the unit away from the exhaust pipes and vents.
  - Follow the recommended compass safe distances shown on page i to prevent interference to a magnetic compass.
1. Drill four pilot holes ( $\phi 4 \times 16$ ), referring to the outline drawing at the back of this manual.
  2. Set the incoming volume on the rear of the telephone before the telephone is fixed to the mounting location.

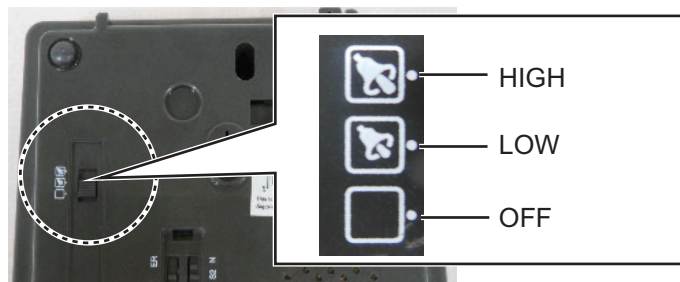

3. Turn the hook upside-down, as shown in the figure below, then re-insert the hook at its original location. A "click" sound indicates that the hook is inserted correctly.

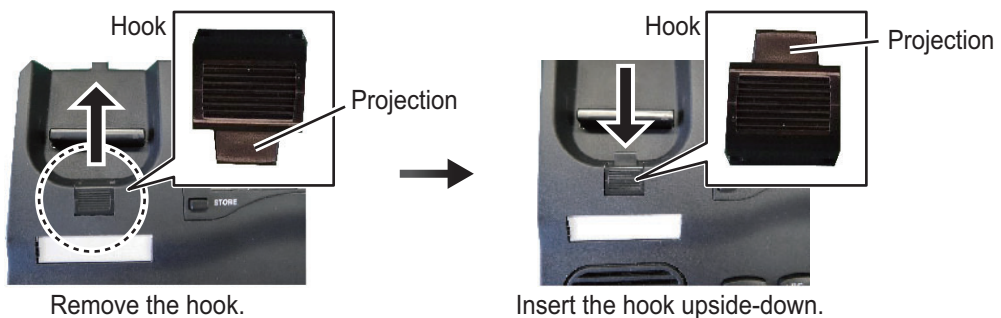

4. For installations using the tilted fixing base on a desktop, attach the supplied rubber foot (2 pcs) to the bottom of the fixing base.

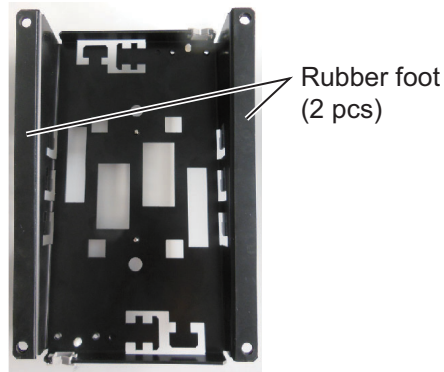

5. Turn the telephone over and lay the fixing base on the telephone. The shape of the horizontal and tilted fixing bases are different. Fit the fixing base so that the holes (dashed-circle in the figure below) of the telephone and fixing base overlap. **Note:** The titled fixing base has one hole at either end and can be mounted to the telephone in either direction.

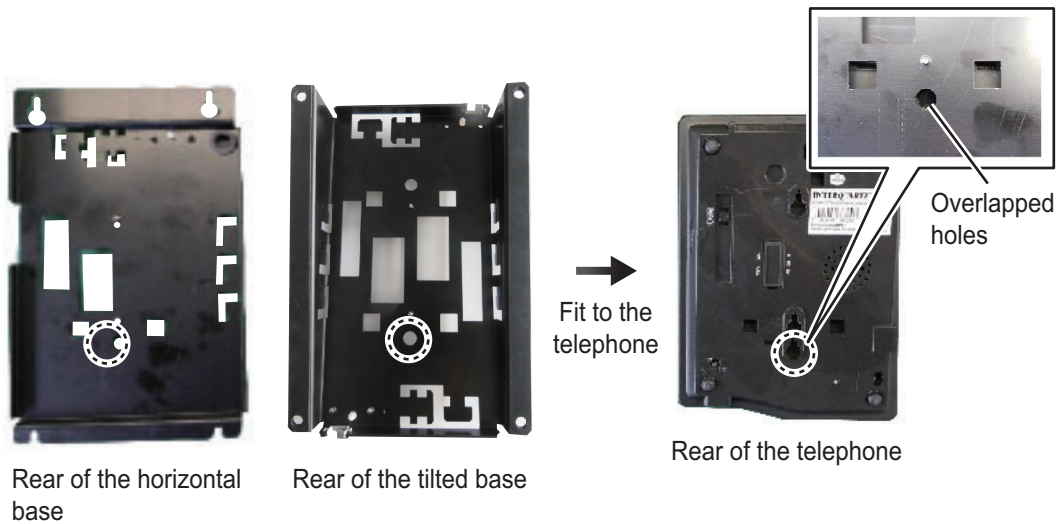

6. Move the fixing base in the arrow direction shown in the figure below until the the fixing base stops, holding the telephone. Make sure that two square holes of the telephone and fixing base overlap.

**Note:** If the fixing base is difficult to move due to a hard fit, press the × position to bend the fixing base.

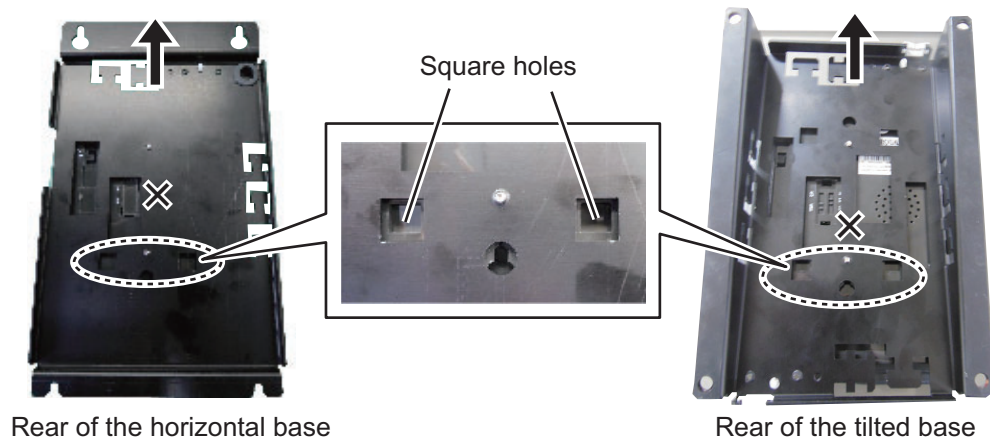

1. HOW TO INSTALL THE UNIT

7. Attach the handset fixture (supplied) to the fixing base with two binding head screws (M4×10, supplied).

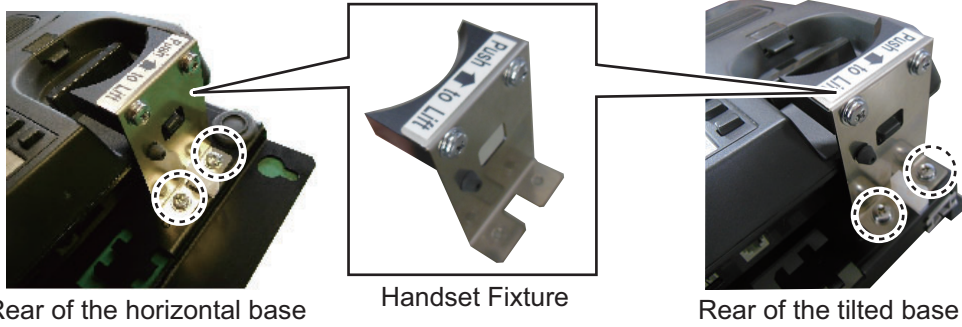

8. Unwind the cord of the handset near the connector, and attach three EMI cores (supplied) on the unwound cord.

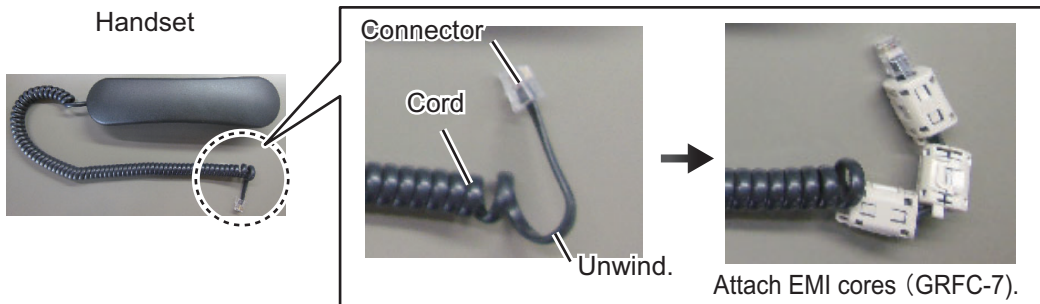

9. Insert the connector of the handset cord to the side of the telephone. Fix three EMI cores to the fixing plate with the cable ties (supplied), then cut any excess cable tie. Push the handset securely to fit the cradle.

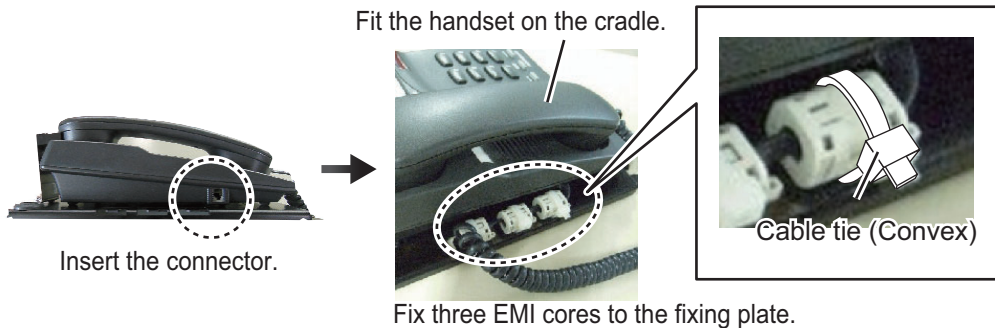

10. Pass the cable from the bottom of the fixing base.

Horizontal fixing base:

Make a hole in the grommet then pull up the cable through the grommet from the bottom.

Tilted fixing base:

Pull up the cable through the edge saddle from the bottom.

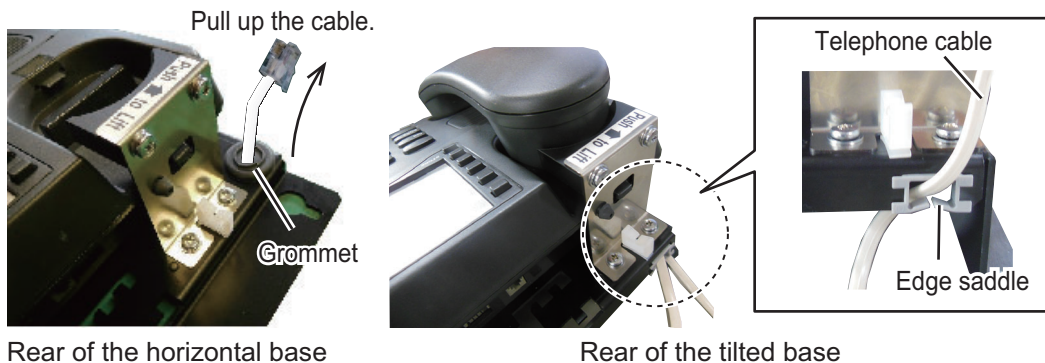

11. Attach two EMI cores on the cable as below.

- EMI core GRFC-7: Attach the EMI core near connector of the cable
- EMI core GRFC-13: Attach the EMI core leaving approx. 40 mm from the EMI core GRFC-7 with the cable wound around the EMI core three times, as shown in the figure below.

**Note:** When winding the cable around the EMI core, leave enough slack in the cable to allow a cable tie to pass between the EMI core and the cable.

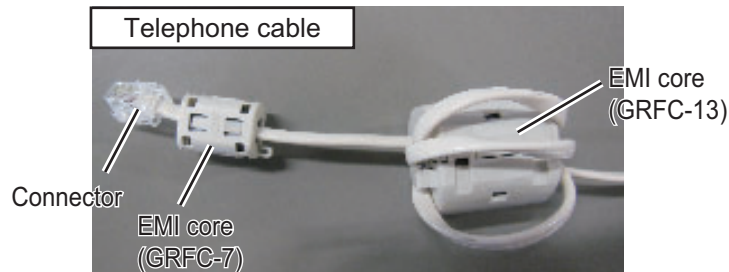

12. Secure the fixing base to the mounting location with four self-tapping screws ( $\phi 5$ , supplied).

13. Insert the connector of the telephone cable to the LINE entrance.

14. Fix two EMI cores to the fixing base, and press the cable down on the cable clamp to pass the cable through the cable clamp. Cut any excess cable ties.

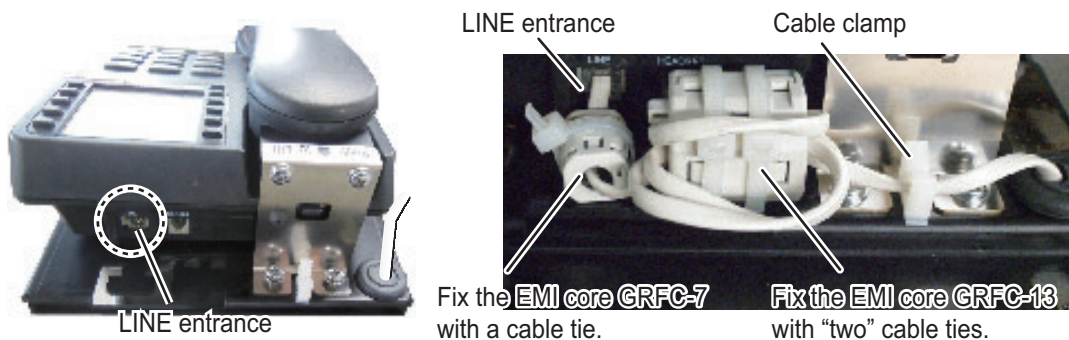

15. Confirm that the handset can be picked up as shown in the figures below.

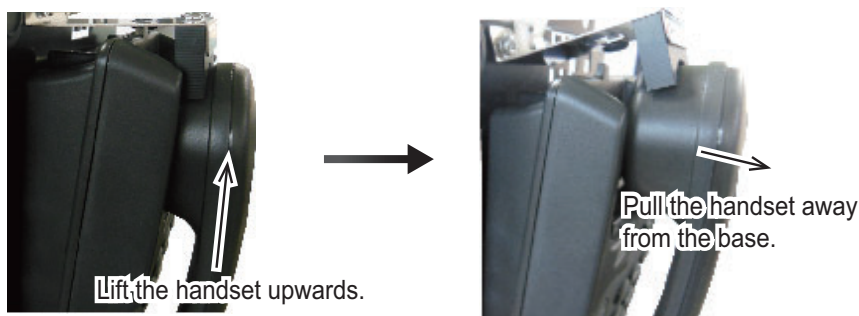

16. Set the volume for an incoming call as required.

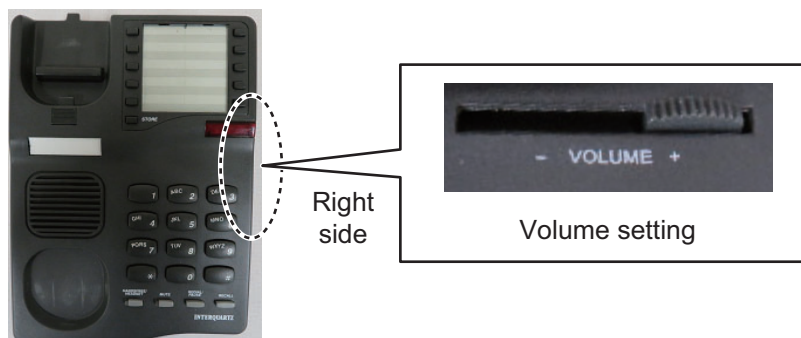

## 1.6 Facsimile FAX-2840 (Option)

1. Set the facsimile on the mounting location.
2. Set a fixing plate (supplied) to both the right and left sides of the facsimile as shown in the right figure.

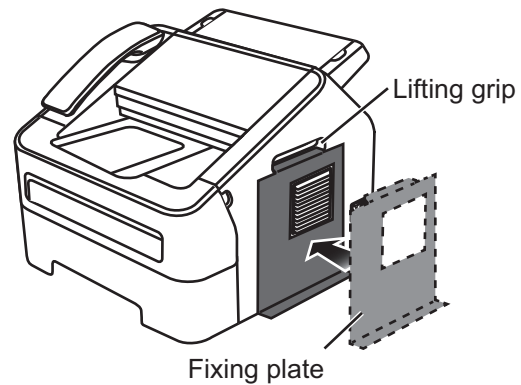

3. Fasten the fixing plates to the mounting location with self-tapping screws (supplied).

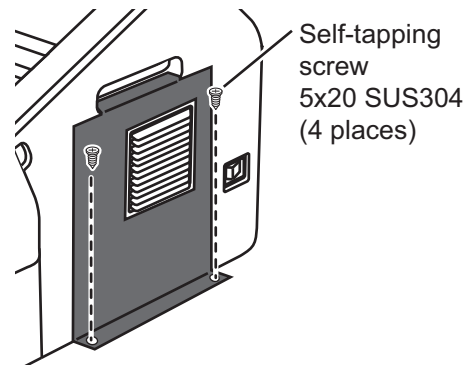

4. Attach the compass safe distance label at the location shown in the right figure.

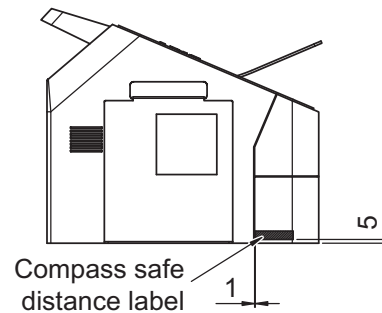

5. Attach the supplied label ("INMAR") to a noticeable location.

### How to change modem settings

1. Press [Menu], [\*], [2], [8], [6] and [4] keys in this sequence to enter the maintenance mode.  
The fax machine beeps for approximately one second and displays "MAINTENANCE" on the LCD. This means the FAX is in the initial stage of the maintenance mode.
2. Press [1] and [0] keys in this order. "WSW00" is displayed on the LCD.
3. Press [1] and [3] keys in this order. "WSW13=00011011" appears on the LCD.
4. Press [0], [0], [0], [1], [1], [0], [1], [0] and [OK] keys in this order. "WSW00" appears on the LCD.
5. Press [1] and [9] keys in this order. "WSW19=11100000" appears on the LCD.
6. Press [1], [1], [1], [0], [0], [0], [1], [0] and [OK] keys in this order. "WSW00" appears on the LCD.
7. Press [Stop/Exit] key to return the machine to the initial stage of the maintenance mode.
8. Press [9] key twice to exit from the maintenance mode and return to standby. "Please Wait." appears then return the normal display.



## 1.7 Incoming bell (Option)

Select a location for the incoming bell by following the information shown below. You can connect one analog telephone to the incoming bell.

- Keep the unit away from water splash.
- Keep the unit away from direct sunlight.
- Set the unit away from exhaust pipes and vents.
- Follow the recommended compass safe distances shown on page i to prevent interference to a magnetic compass.

### How to install on the bulkhead

1. Fabricate the TTYCS-1 cable (local supply).

The crimp-on lugs for the incoming bell and communication unit are included in the installation materials for the incoming bell. The crimp-on lugs for the modular jack box are included in the installation materials for the modular jack box (optional supply).

For communication unit

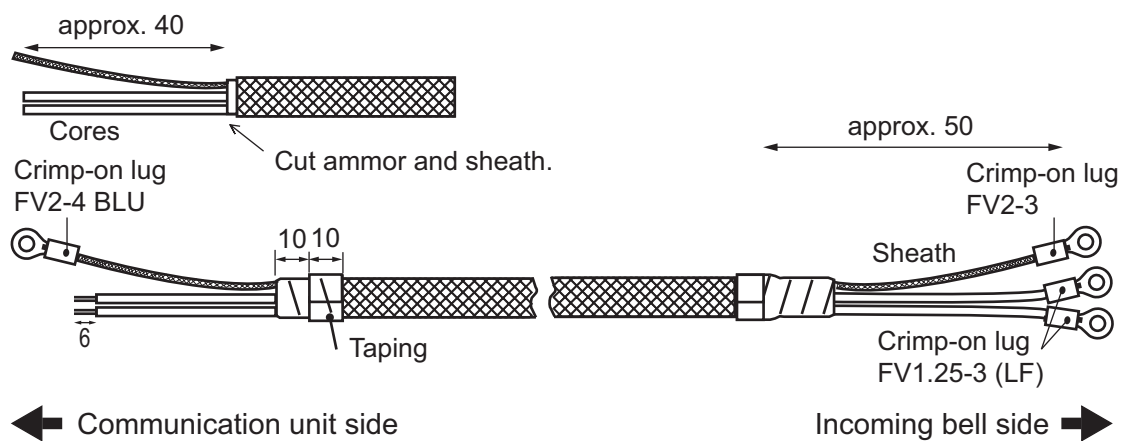

For telephone and facsimile

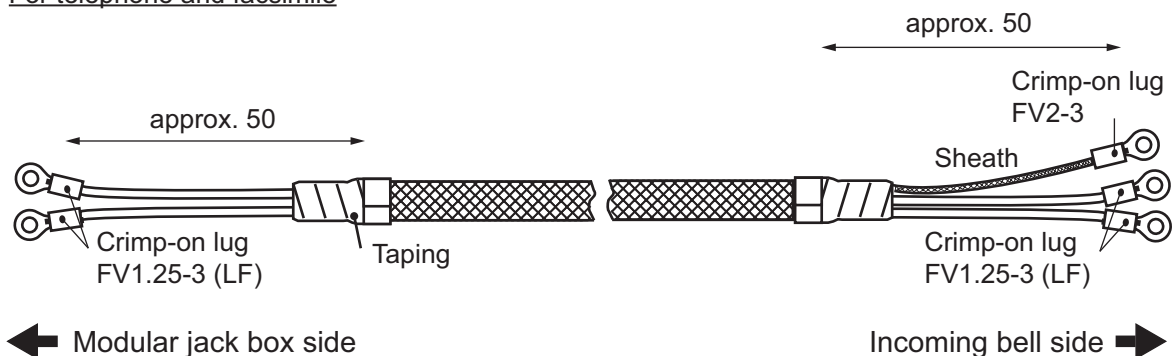

2. Remove the four screws on the front cover, then remove the cover.
3. Secure the case to the installation location with four 3×10 self-tapping screws (supplied). See the outline drawing at the back of this manual for the fixing hole locations.

## 1. HOW TO INSTALL THE UNIT

4. Connect the cables, fabricated at step 1, to the incoming bell's terminals.

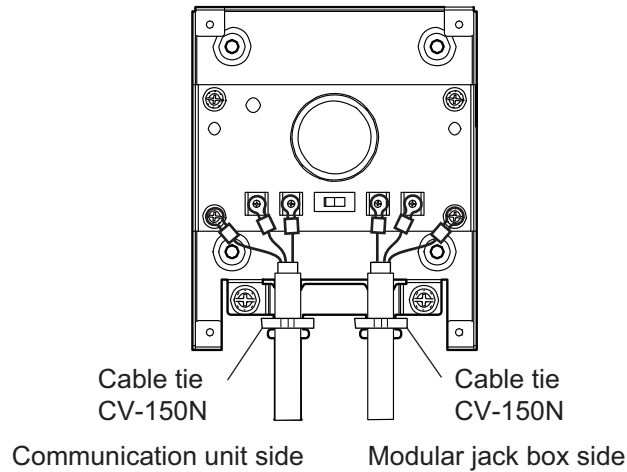

5. Fasten the cables to the cable fixture with the cable ties (supplied).
6. Connect the cables with the FMC connector on the communication unit.

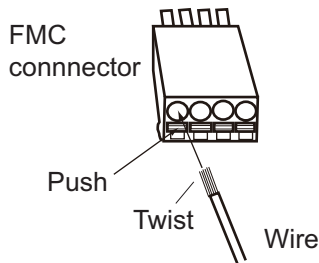

### Procedure to insert wire

1. Twist core.
2. Push spring-loaded catch with slotted-head screwdriver.
3. Insert core into hole.
4. Release the screwdriver.
5. Pull wire to confirm it is securely inserted.

7. The cover of the incoming bell has protective seals on the cable entries. To remove the seals, tear along the perforated lines on the inner side of the cover.
8. Reattach the lid to the case with the four screws removed at step 2.

### How to attach Splash proof cap

When installing the incoming bell on a bulkhead, use the optional splash proof cap (Type: 16-023-5501/Code No.:001-493-320) to help keep water out of the unit. With the splash proof cap attached, this unit has an waterproof rating of IP22.

**Note:** The splash proof cap cannot be used if the incoming bell is mounted face upward.

Remove the seal from the splash proof cap and attach the cap as shown in the illustration to the right.

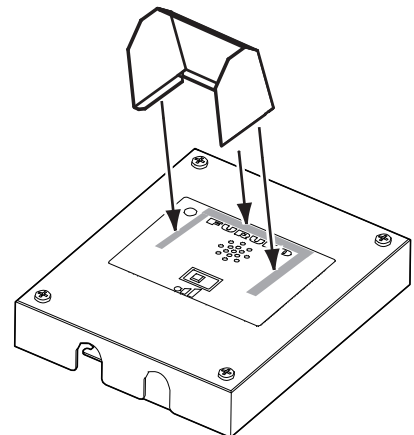

# 2. CONNECTIONS

## 2.1 Standard Connection

Run and connect cables, referring to the figure below and the interconnection diagram (page S-1).

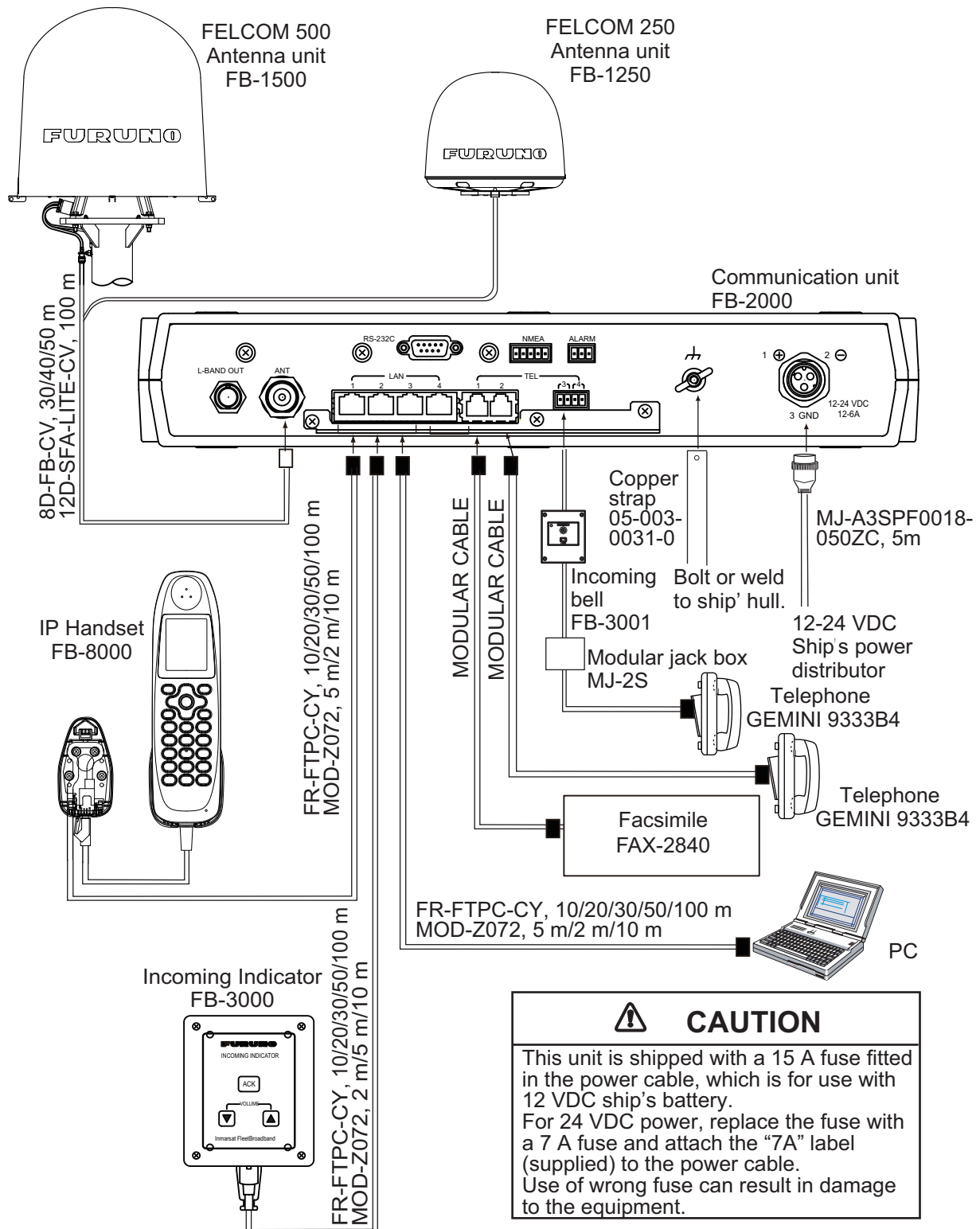

## 2.2 Antenna Cable

Run the antenna cable (coaxial cable 8D-FB-CV, 30 m, 40 m or 50 m supplied) between the antenna unit and Communication Unit. Attach the connector plug of the antenna cable to the antenna unit. Connect the coaxial connector (8D-FB-CV) to the other end of the antenna cable.

If the attachment is present, attach the coax connector from the antenna unit there. If there is no attachment, connect the coax plug at the bottom of the antenna unit.

Wrap the junction point of connectors with the self-adhesive tape then vinyl tape. Bind the ends of tape with a cable tie (local supply). Fix the cable to the mast with a cable tie (local supply).

If the distance between the antenna unit and Communication Unit is 50 m or more, use cable 12D-SFA-LITE-CV (max. 100 m).

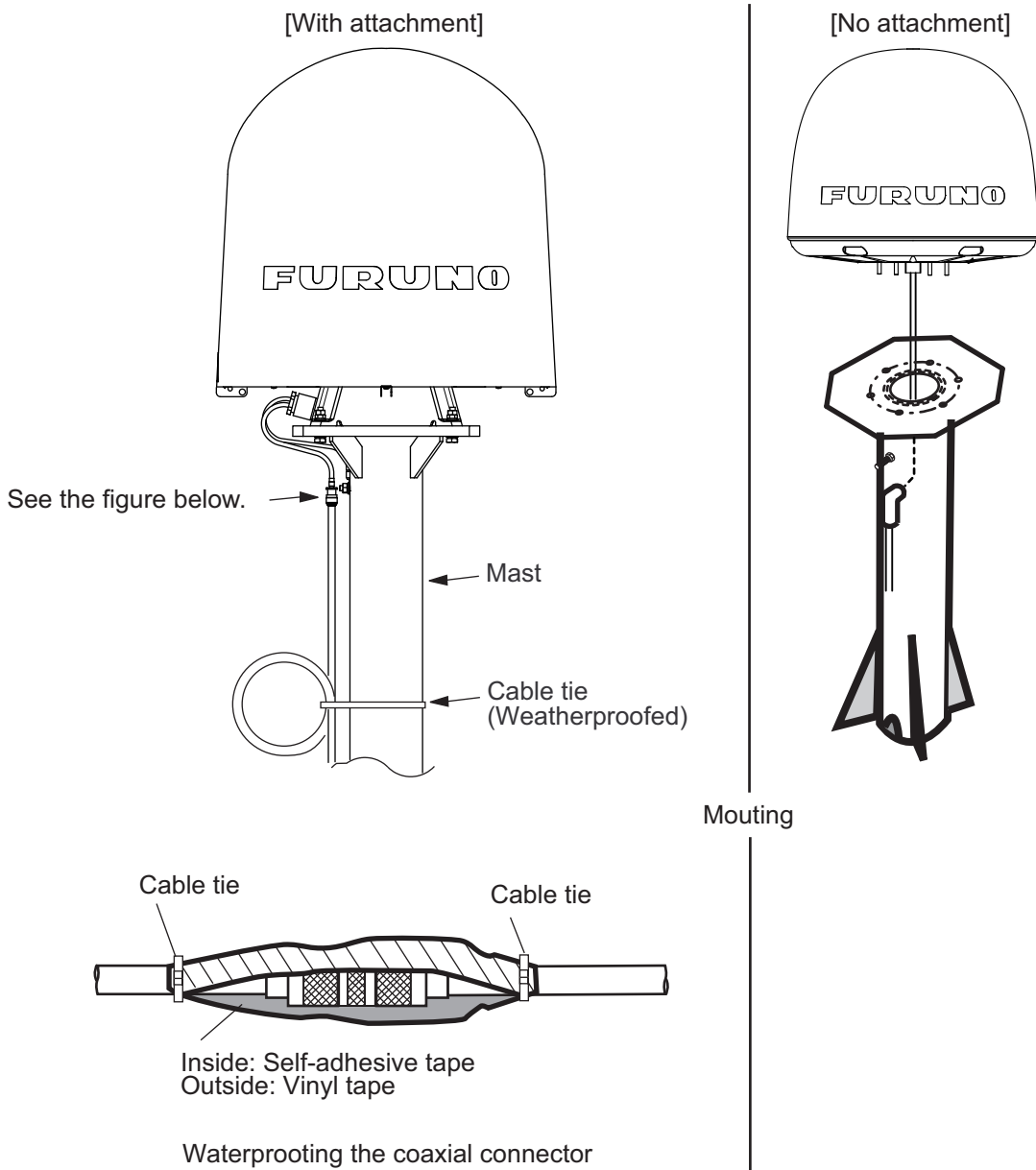

**How to attach the antenna cable connector N-P-8DFB-1-CF**

Attach the coaxial plug (supplied) to the other end of the coaxial cable to connect to the CU as follows.

(Dimensions in millimeters.)

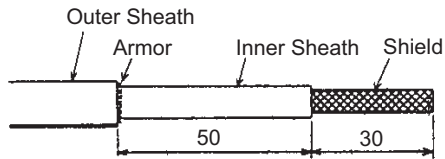

Remove outer sheath and armor by the dimensions shown left. Expose inner sheath and shield by the dimensions shown left.

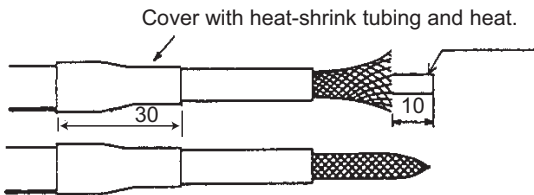

Remove insulator and core by 10 mm.

Twist shield end.

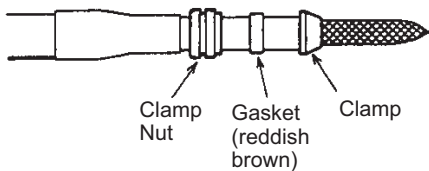

Slip on clamp nut, gasket and clamp as shown left.

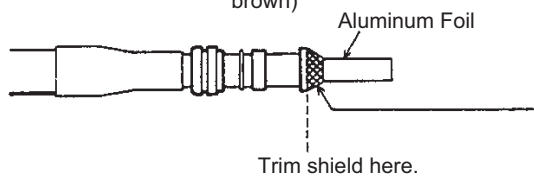

Fold back shield over clamp and trim.

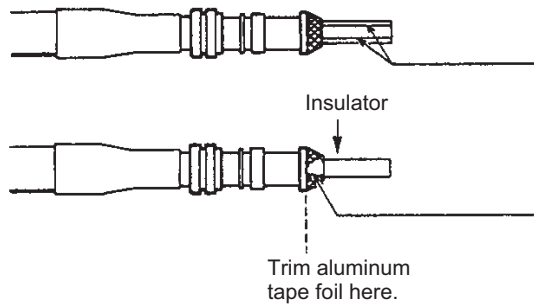

Cut aluminum foil at four places, 90° from one another.

Fold back aluminum tape foil onto shield and trim.

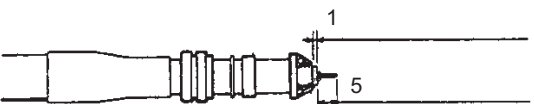

Expose the insulator by 1 mm.

Expose the conductor (core) by 5 mm.

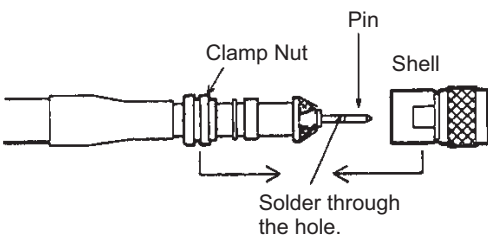

Slip the pin onto the conductor. Solder them together through the hole on the pin.

Insert the pin into the shell. Screw the clamp nut into the shell. (Tighten by turning the clamp nut. Do not tighten by turning the shell.)

## 2. CONNECTIONS

### **How to attach the antenna cable connector N-SP-12DSFA-CF**

If the optional coaxial cable 12D-SFA-LITE-CV (100 m) is used, attach the optional coaxial plug N-SP-12DSFA-CF as follows.

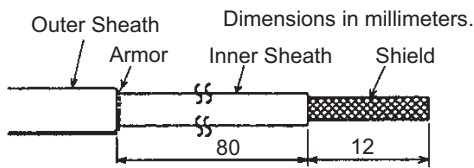

Remove outer sheath and armor by the dimensions shown left.  
Expose inner sheath and shield by the dimensions shown left.

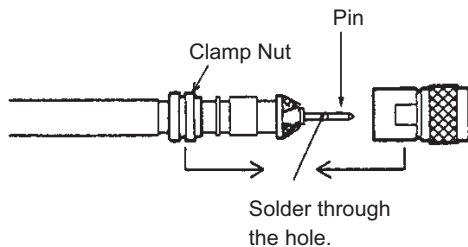
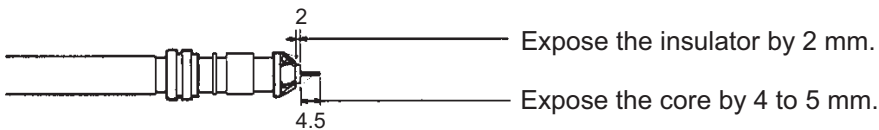
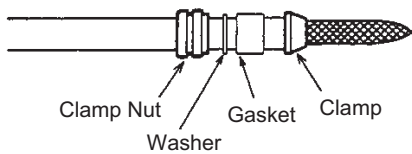
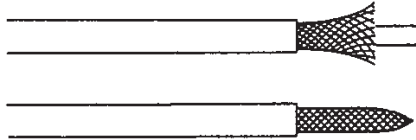

## 2.3 Communication Unit

### Telephone GEMINI 9333B4 and Facsimile FAX-2840

Connect the cable from the telephone or facsimile to TEL1, 2, 3 or 4 port of the Communication Unit. The modular connector can be connected directly to the TEL1 or TEL2 as shown in the figure below.

To connect to the TEL3 or TEL4, use the modular jack box (optional supply) or the modular jack set (optional supply). Connect TTYCS-1 (Japan Industry Standard cable, or equivalent, local supply) between the modular jack box and Communication Unit. Attach two crimp-on lugs (FV1.25-3 red, supplied with the modular jack box) to the modular jack box side of the above cable

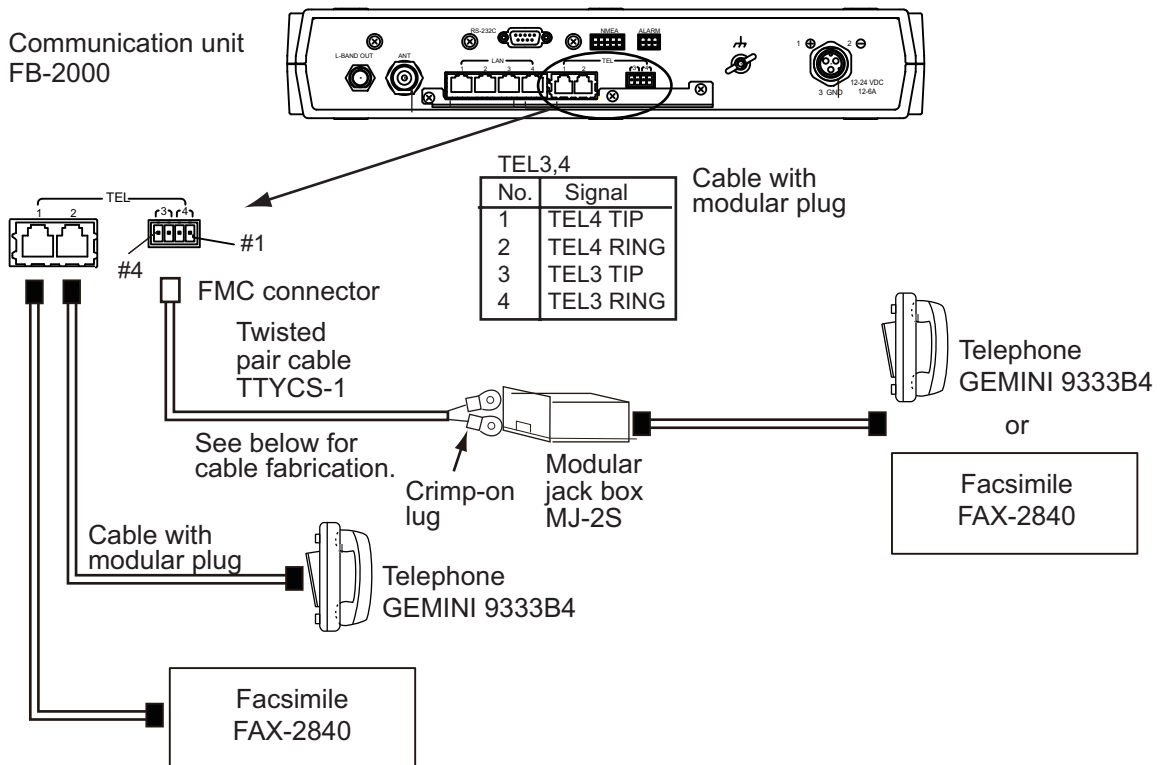

### TTYCS-1 Cable fabrication

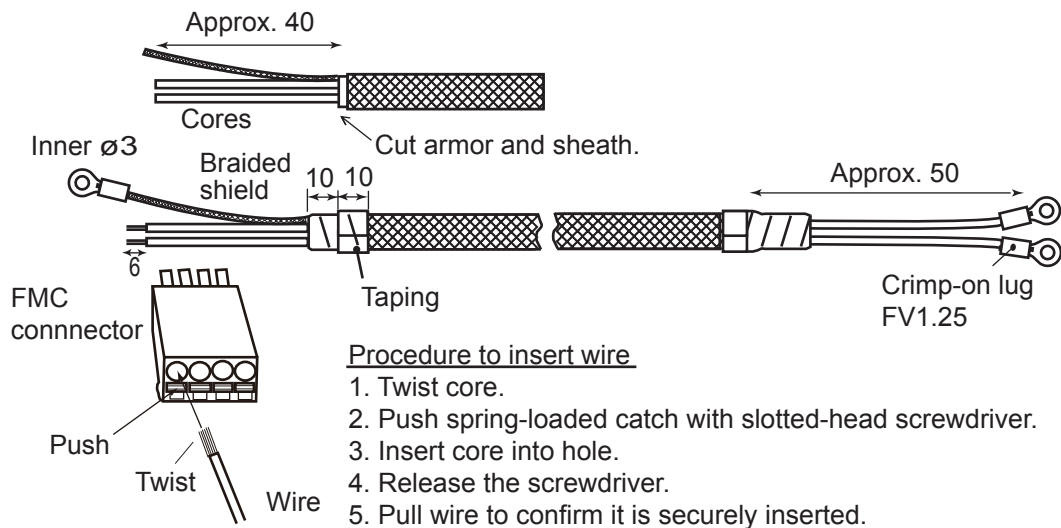

2. CONNECTIONS

**NMEA signal, External alarm**

Communication unit  
FB-2000

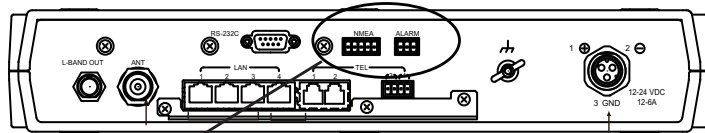

NMEA	
No.	Signal
1	TD-A
2	TD-B
3	RD-A
4	RD-B
5	GND

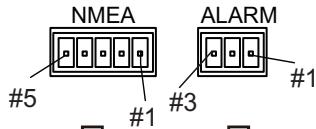

ALARM	
No.	Signal
1	NC-A
2	NC-B
3	GND

See the figure on previous page for how to fix FMC connector.

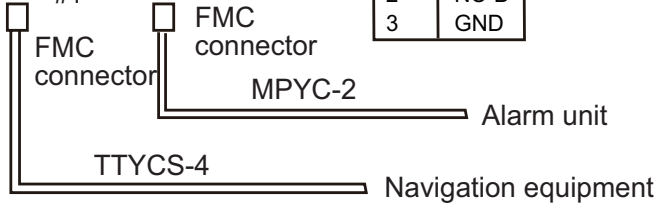

NMEA input sentence  
GGA, GLL, GNS, RMA, RMC, VTG, ZDA  
(Talkers for GNS are GN, GP and GL only.  
For other sentences any talker will do.)

**Cable fixture**

To connect the LAN and TEL lines, attach the cable fixture (supplied) to the rear panel of the Communication Unit. Then insert the connectors to each port. Fasten each cable with a cable tie (supplied) to the cable fixture. Connect the braided shield wire of each cable to the ground terminal.

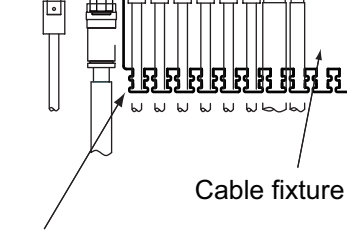
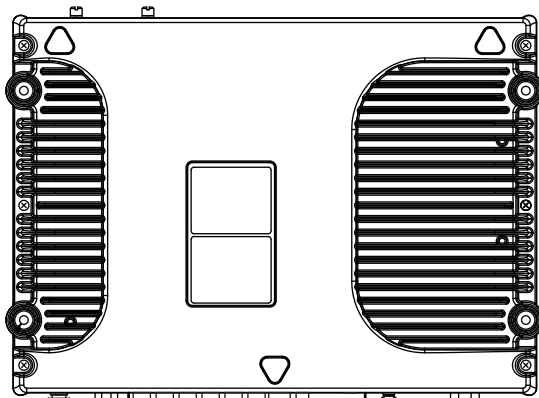

Fasten cable to this post of cable fixture with a cable tie.

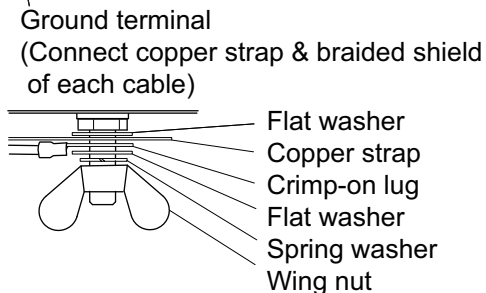



## 2.4 Notice for network connection

With a hub(s), FELCOM500/FELCOM250 can establish a network configuration. If the hub(s) is connected in loop form, the FELCOM500/FELCOM250 may not function normally.

### Never connect as follows:

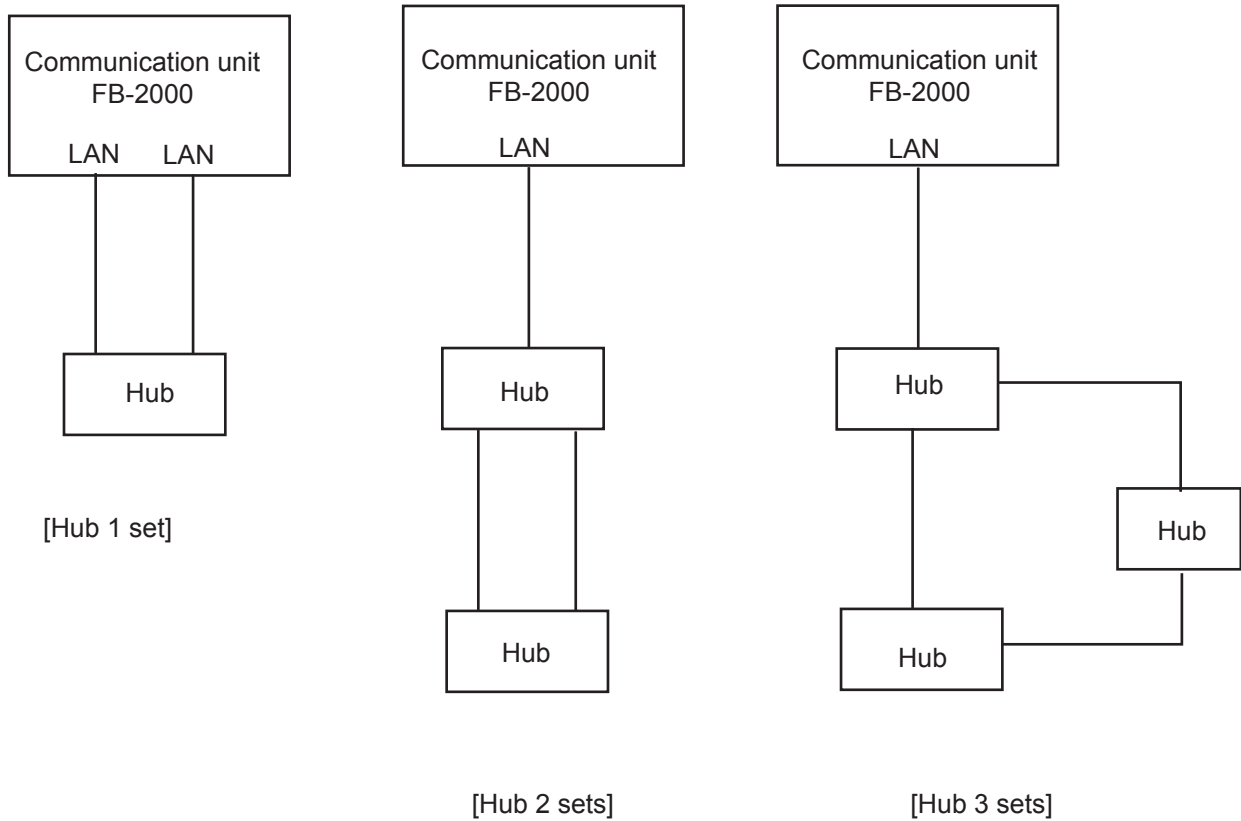

**Note:** If you install a switching hub that does not have an automatic function to distinguish straight/cross (MDI/MDI-X) connections, you will need to select a proper cable:

- Use a straight connection cable for an MDI to MDI-X connection.
- Use a cross connection cable for an MDI to MDI or MDI-X to MDI-X connection.

Generally, it is advisable to use an auto MDI/MDI-X switching hub.

## 2.5 Desktop Installation of Communication Unit to comply with IPX2 (dripping) standard

### How to inset the grommet

Be sure to install the Communication Unit to a desktop to protect from dripping. After installing, affix the grommets over the mounting screws.



Grommet inset  
(4 grommets)

### How to install the connector cover

After connecting the cables, perform the following to affix the connector cover.

1. Peel off the double sided tape (white) from the connector cover.

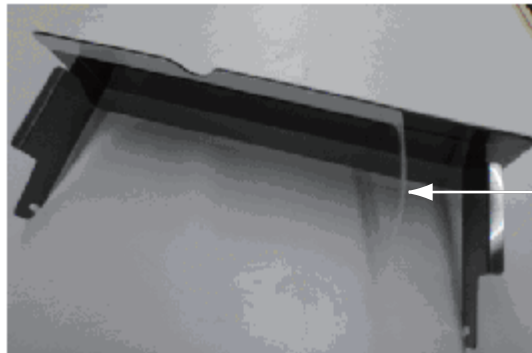

Tape

2. Plug the guide rail of the connector cover into the slots as shown, and pull slightly to hook into the slot.

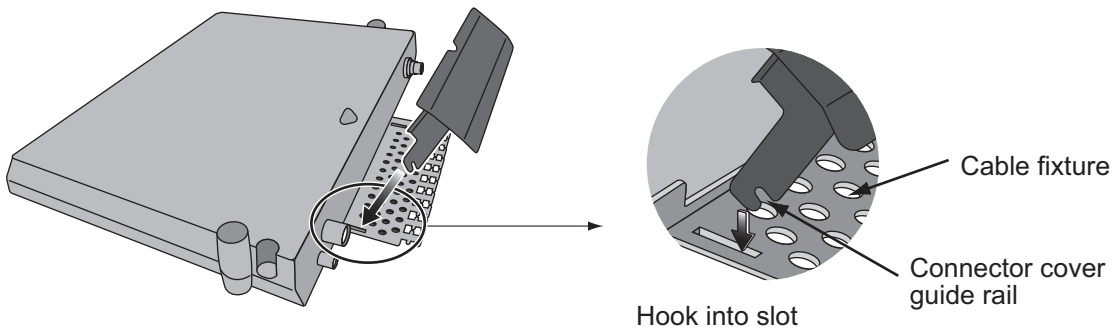

3. With the connector cover rail in the slot, raise the connector cover in the direction of the arrow as shown below.

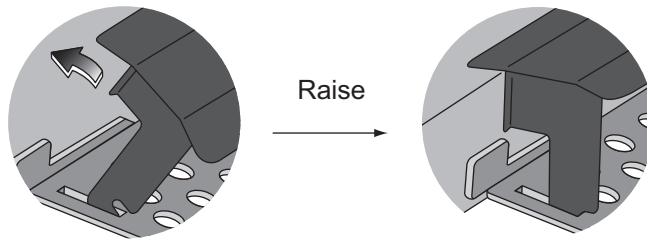

4. Push the connector cover in towards the triangle mark on the center top of the Communication Unit to affix.

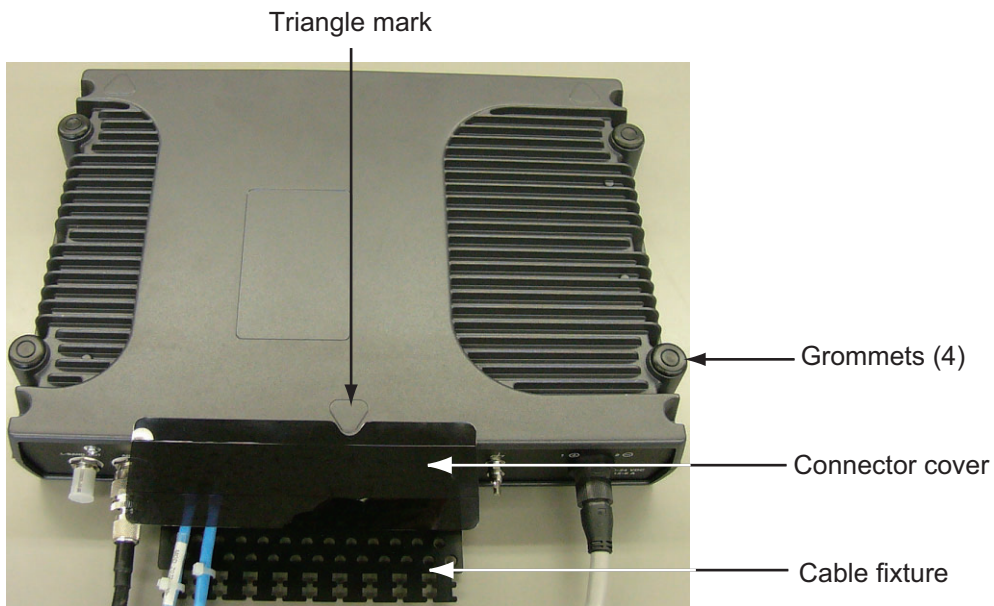
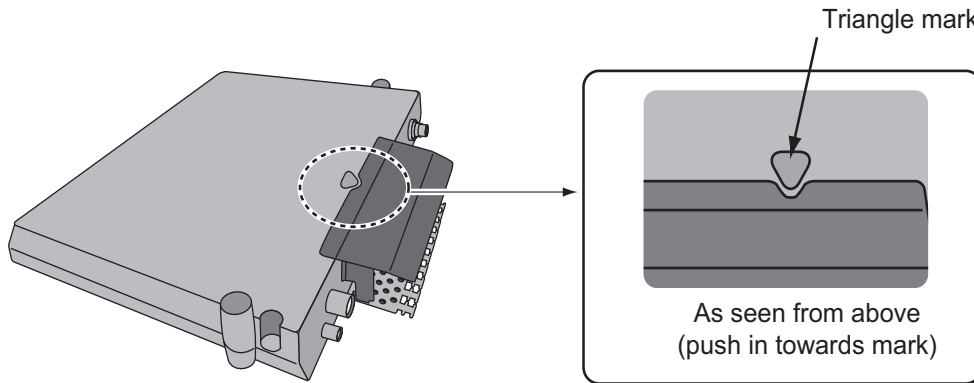

## 2.6 LAN Cable Fabrication

Fabricate an optional LAN cable (FR-FTPC-CY 10, 20, 30, 50 or 100 m) as follows. Cut armor and outer vinyl sheath as shown below and then connect the modular connector MPS588-C (option) to both ends.

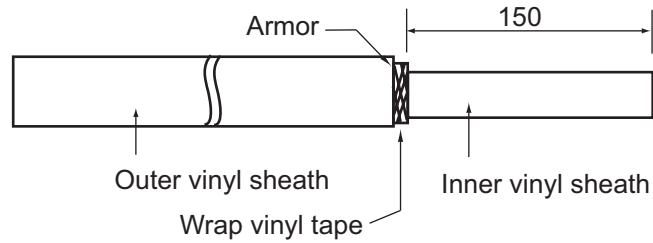

Expose inner vinyl sheath.

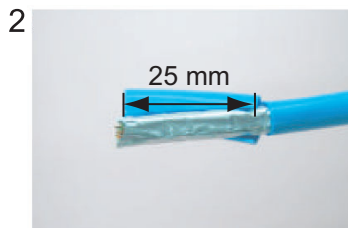

Remove the inner vinyl sheath by approx. 25 mm. Be careful not to damage inner shield and cores.

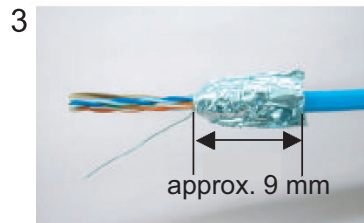

Fold back the shield, wrap it onto the inner vinyl sheath and cut it, leaving approx. 9 mm.

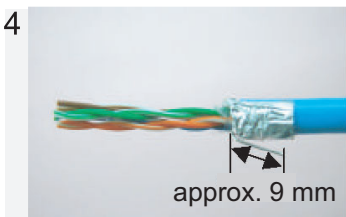

Fold back drain wire and cut it, leaving approx. 9 mm.

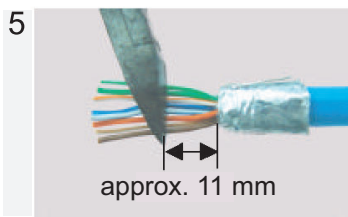

Straighten and flatten the cores in colored order and cut them, leaving approx. 11 mm.

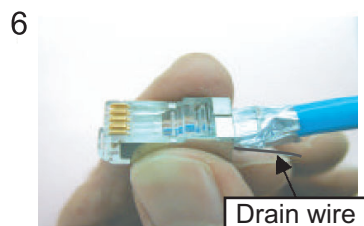

Insert the cable into the modular plug so that the folded part of the shield enters into the plug housing. The drain wire should be located on the tab side of the jack.



Using special crimping tool MPT5-8AS (PANDUIT CORP.), crimp the modular plug. Finally, check the plug visually.

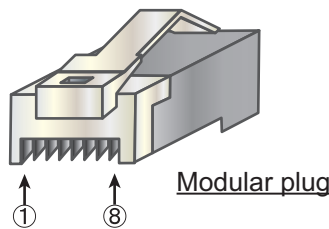

[Crossover cable]

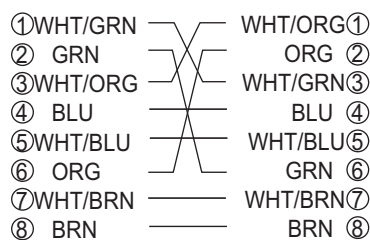

[Straight cable]

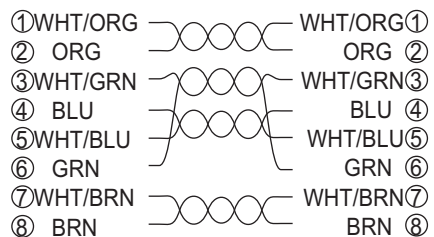

# 3. SETTING AFTER INSTALLATION

This chapter shows how to enter basic settings, done by the installation technician. For the network setting, request to an administrator of the ship network. (Refer to the Operator's Manual for details.)

The SIM card is required to communicate via a satellite, but not required for the following system settings. "(SIM): No SIM" appears in the Web software screen. Disregard the warning.

## 3.1 Preparation for Setting

1. Connect the PC to the Communication Unit with a LAN cable.
2. Turn on the PC.  
**Note:** Set the Internet Protocol (TCP/IP) Properties of PC to "Obtain an IP address automatically". If you set the PC IP address manually, set it according to the IP address of the Communication Unit (default 192.168.1.1).
3. Turn on the Communication Unit.  
The initialization begins. During this time, the PC cannot access the Communication Unit.

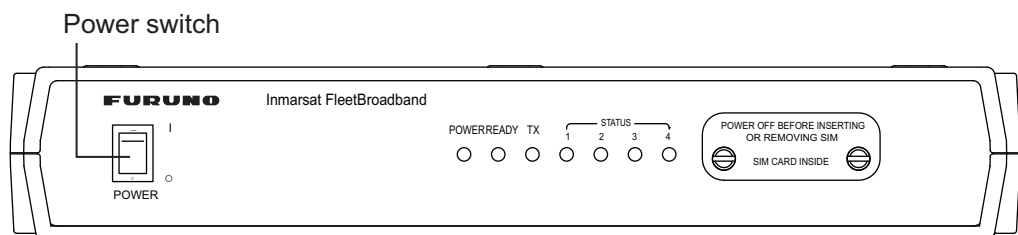

Communication unit

4. When all STATUS LEDs are lit, activate the Web browser.
5. Enter "192.168.1.1" in the address bar and press the **Enter** key.  
The main menu of the Web software opens.  
**Note:** You can add the main menu of the Web software to "Favorite" or "Bookmark" for easy access.

### 3. SETTING AFTER INSTALLATION

For FELCOM 250, "FELCOM 250" is indicated.

Administrator Login

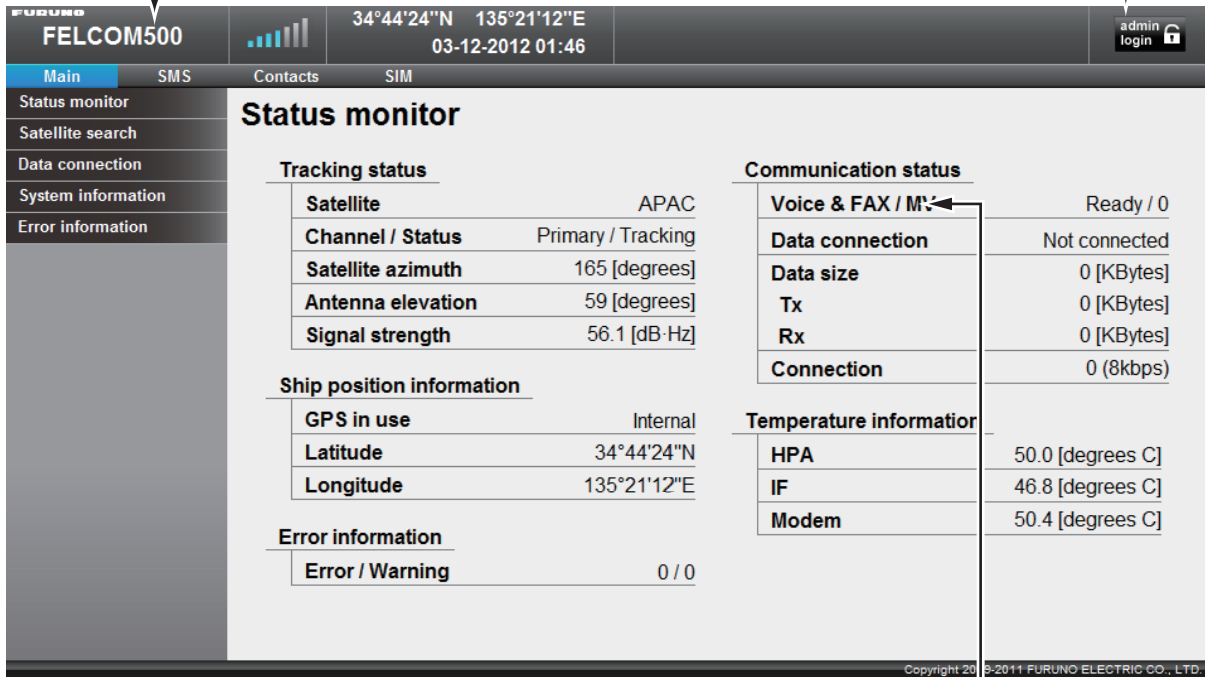

"MV" requires a contract with the provider.  
See our FURUNO web site ([www.furuno.com](http://www.furuno.com))  
for details.

6. Click the [admin login] button at the upper right hand side on the screen to show the Login window.
7. Key in username "Admin" and passSword "01234567" (default value).  
The administrator can change the password in another menu.

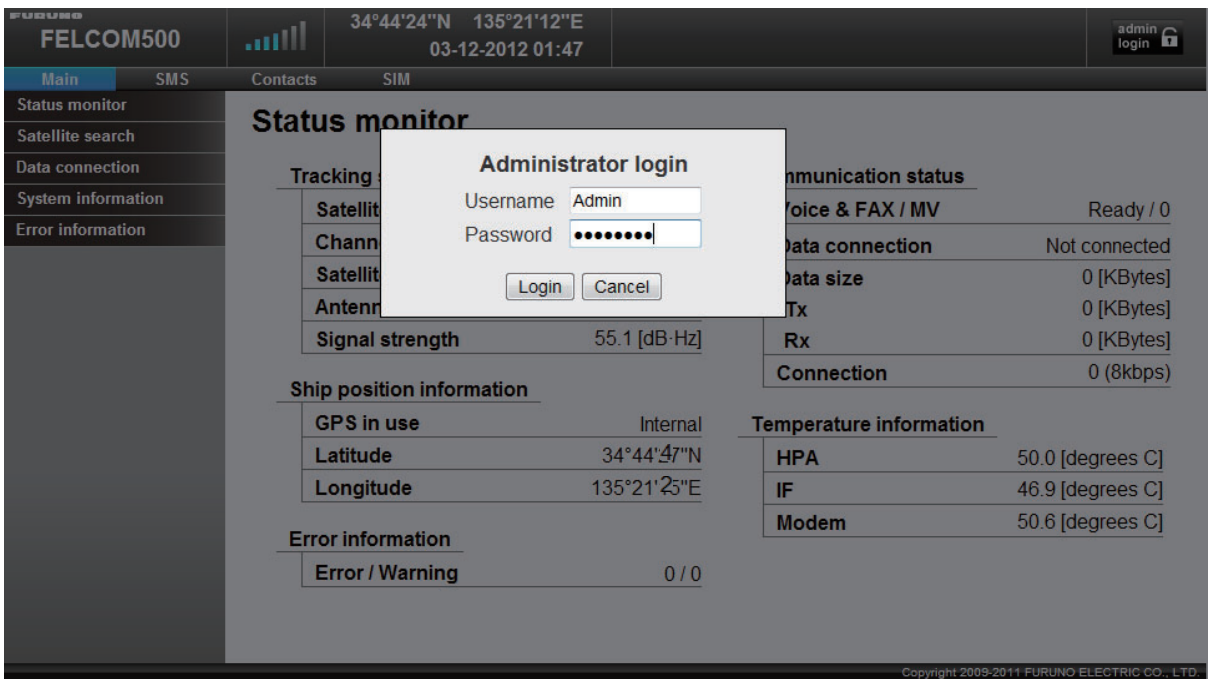

8. Click the [Login] button.  
New menu items appear on the menu bar; Log, Settings, Device, and Selftest.

- Click [Settings] on the menu bar.  
The sub menu appears at the left side and the current setting appears in the Information window at the right side.

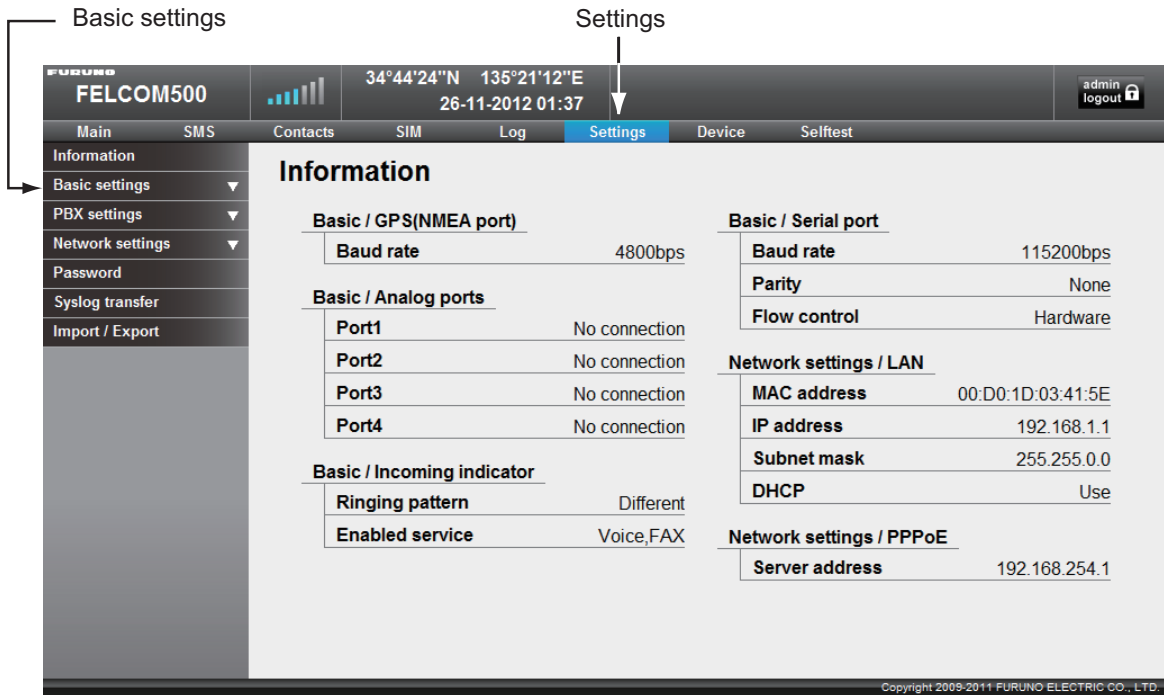

- Click [Basic settings] on the sub menu to show the list of basic settings sub menus.

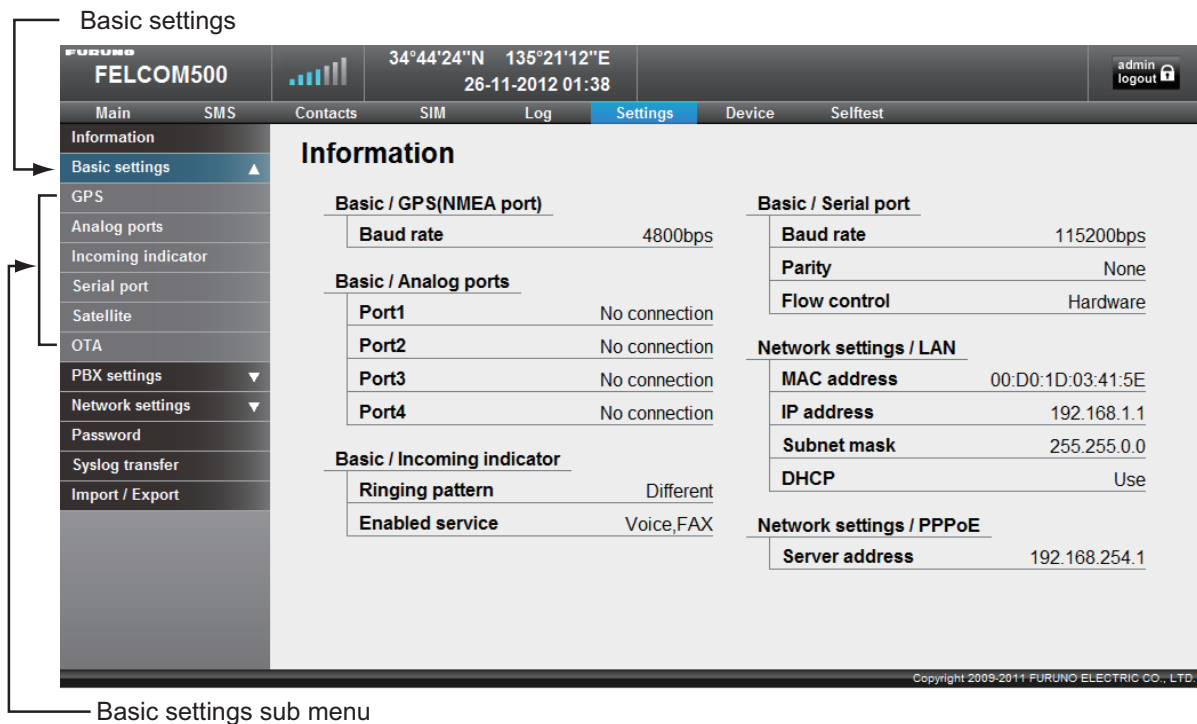

Use these sub menus to set the basic settings, following the procedures on the next several pages.

## 3.2 GPS Setting

1. Click [GPS] on the Basic settings sub menu.

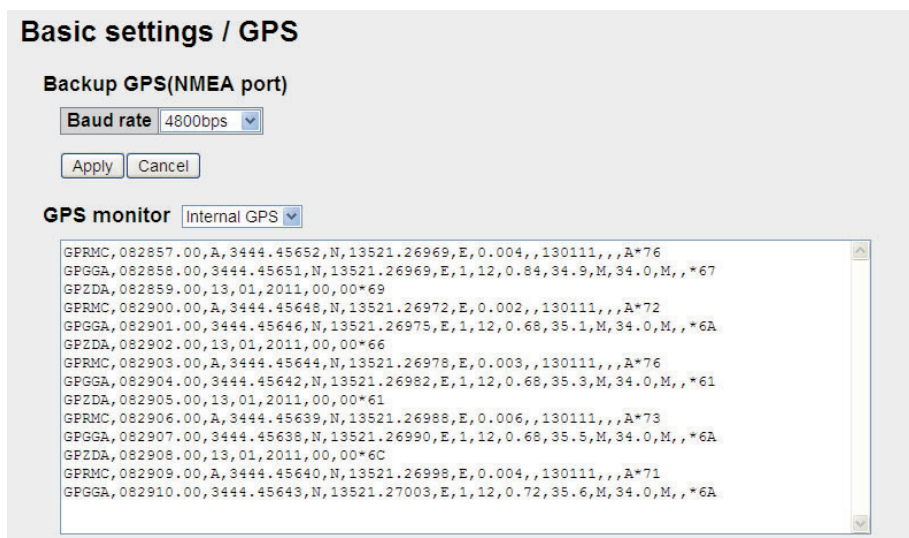

2. If an external GPS is connected to the NMEA port on the Communication Unit, set the baud rate to 4800 bps or 38400 bps according to the GPS connected.
3. Click the [Apply] button.
4. To monitor output sentences from the GPS, select a GPS among Internal GPS, NMEA port, and None. "None" displays no sentences.



## 3.3 Analog Port Setting

Set for analog telephones/faxes that are connected to the TEL ports as follows.

1. Click [Analog ports] on the Basic settings sub menu.

**Basic settings / Analog ports**

P	Type	Number	Note	Voice ring		Fax ring		Call limit	Access	Filter	
				1st	2nd	1st	2nd				
1	No connection							None			[Edit]
2	No connection							None			[Edit]
3	No connection							None			[Edit]
4	No connection							None			[Edit]

The background color of the "2nd ring" column is yellow when the "2nd ring" of more than one terminal (incl. PBX settings/Extension) is enabled. In this case, ringing stops after the 1st ring at terminals that do not have "2nd" checked.

2. Click the [Edit] button on the right side of the port to set.  
There are four TEL ports (TEL 1 to TEL 4), and TEL 1 is analog port 1 in the table.

**Basic settings / Analog port 1 / Edit**

Type	No connection
Number(1000-9999)	
Note	
Voice ring	<input type="checkbox"/> 1st (when incoming call) <input type="checkbox"/> 2nd (after 1st ring)
Fax ring	<input type="checkbox"/> 1st (when incoming call) <input type="checkbox"/> 2nd (after 1st ring)
Call limit	No limit
Access code	<input type="checkbox"/> Required
Call filter for outside call	<input type="checkbox"/> Enabled(Numbers accepted to call should be in boxes below.) <input type="text"/> <input type="text"/> <input type="text"/> <input type="text"/> <input type="text"/>

To match completely, please input '#' at the end of the number.

[Save] [Cancel]

3. In the [Type] box, select the equipment that is connected to the TEL port. The selections are as follows:
  - TEL: Analog telephone
  - FAX: Facsimile
  - TEL & FAX: Facsimile telephone
  - No Connection: Nothing connected
4. Key in extension telephone number in the [Number] box. The setting range is between 1000 and 9999.
5. In the [Note] box, key in a name; user name, setting location, etc. This is the name a called party sees. Up to 50 alphanumeric characters can be used. Do not use symbols, "?", "/", etc.
6. Set up outside line calls in the [Voice ring] box.  
If you selected TEL at step 3, "1st" is checked. Then, any terminals that have "1st" checked ring first. Remove the check for no ring. Check "2nd" to ring 2nd terminal when there is no answer at the terminal that has "1st" checked. Ring duration time can be set on the [2nd ring timer] of the PBX settings/General settings screen. (See the operator's manual.)

### 3. SETTING AFTER INSTALLATION

7. Set up fax call in the [Fax ring] box. (Same as the Voice ring.)  
If you selected FAX or TEL&FAX at step 3, "1st" is checked.
8. Set the transmission limit in the [Call limit] box.
  - No limit: No transmission limit.
  - Extension only: Transmission available for extension call only.
  - Incoming only: Outgoing call not available. Incoming call only.
  - Outside only: Transmission available for external call only.
9. If checked [Access code], requires input of access code to access an outside line. The Caller ID is recorded to the Voice Call log to identify the person accessing the outside line.  
**Note:** Access code requirement cannot be set in the following cases:
  - When "Extension only" or "Incoming only" is selected in the [Call limit] box (step 8).
  - When "Call filter for outside call" below is enabled.
10. At the [Call filter for outside call] box, set the restrictions for outside calling. Check "Enabled" to activate the restrictions, set in the boxes (a maximum of 20 characters). See the table below for example restrictions. A maximum of five restrictions can be set.

	Usage	Input Example	Remarks
1	Register telephone number of office on the shore.	+81798631131#	Forbid outside calls to other than the phone number registered here.
2	Register only country number (Japan for example).	+81	Permit calls only to Japan.
3	Register the number exclusive use of pre-paid card.	66#	Forbid outside calls other than those made with a pre-paid card.

**Note:** Call filter for outside call cannot be set in the following cases:

- When "Extension only" or "Incoming only" is selected in the [Call limit] box (step 8).
  - "Required" is checked at the "Access code box" (step 9).
11. Click the [Save] button. The message "Setting Completed" appears.
  12. Click the [OK] button to erase the message.

**Note:** If "2nd" is checked on the Basic settings/Analog ports screen or PBX settings/Extension screen, the background color of the 2nd column on the Analog ports screen becomes yellow. In this condition, terminals that do not have "2nd" checked stop ringing after the time specified has elapsed.

## 3.4 Incoming Indicator Setting

If the optional Incoming Indicator is connected, set it as follows.

1. Click [Incoming Indicator] in the Basic settings sub menu.

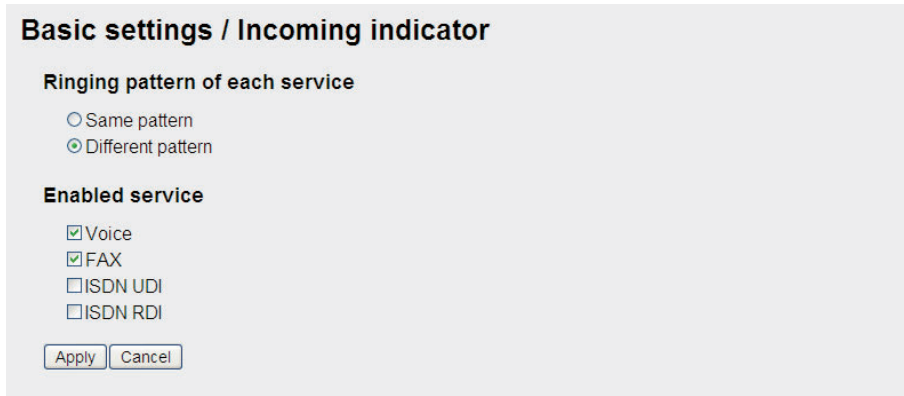

**Basic settings / Incoming indicator**

**Ringing pattern of each service**

Same pattern  
 Different pattern

**Enabled service**

Voice  
 FAX  
 ISDN UDI  
 ISDN RDI

Apply Cancel

2. Select the ringing pattern of the incoming indicator in the [Ringing pattern of each service], between Same pattern and Different pattern.  
Same pattern: Same ringing pattern for any communication service.  
Different pattern: Different ringing pattern for each communication service.
3. Check a communication services to ring the incoming indicator.
  - Voice: Ring for incoming telephone.
  - FAX: Ring for incoming facsimile.
  - ISDN UDI: Ring for incoming ISDN UDI data communication (FELCOM500 only).
  - ISDN RDI: Ring for incoming ISDN RDI data communication (FELCOM500 only).
4. Click the [Apply] button to conclude the setting.

## 3.5 Serial Port Setting

Set for the equipment that is connected to the RS-232C port.

1. Click [Serial port] in the Basic settings sub menu.

**Basic settings / Serial port**

<b>Baud rate</b>	115200bps
<b>Parity</b>	None
<b>Flow control</b>	Hardware

Apply Cancel

2. Select a baud rate from the [Baud rate] drop-down list. The selections are 9600, 19200, 38400, 57600 and 115200 bps.
3. Set a parity bit in the [Parity] box. The selections are None, Even and Odd.
4. Select the [Flow control] among Hardware, Software and None.
5. Click the [Apply] button to complete the setting.

## 3.6 Satellite Setting

The four satellites are named APAC (Asia-Pacific), EMEA (Europe-Middle East-Africa) MEAS (Middle East and Asia) and AMER (America). To change satellite name, do as follows.

1. Click [Satellite] in the Basic settings sub menu.

**Basic settings / Satellite**

ID	Name	Position	Primary	Alternate
05	APAC	143.5E	1537.485	1540.825
07	AMER	98.0W	1537.070	1540.730
03	MEAS	63.9E	1537.420	1540.915
06	EMEA	24.9E	1537.920	1541.115

Apply Cancel

2. Put the cursor in the Name box and enter the name of the satellite (max. 10 characters).
3. Click the [Apply] button to complete the setting.  
The meaning of the table items is as follows.
  - ID: Identification of the satellite
  - Position: Position of the geostationary satellite (longitude)
  - Primary: Frequency of the first global channel of the satellite
  - Alternate: Frequency of the second global channel of the satellite

## 3.7 OTA Setting

OTA stands for Over The Air. The OTA function permits remote management of files in the SIM card.

1. Click [OTA] in the Basic setting sub menu.

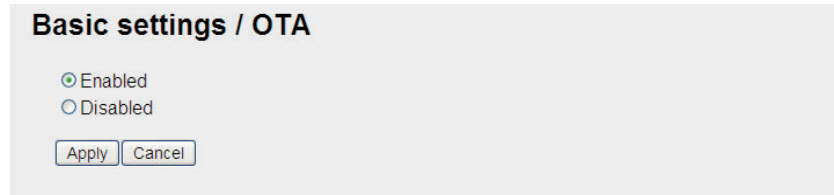

2. To enable the OTA, click the [Enabled] radio button. To disable the OTA, click the [Disabled] radio button.
3. Click the [Apply] button to complete the setting. With Enabled, OTA functions as follows.
  - a) User requests a change of contract contents to a SIM maker.
  - b) The SIM maker transmits an OTA message to the terminal.
  - c) The terminal receives the OTA message and modifies the internal parameters according to the contract contents.

## 3.8 Handset Setting

To use the IP handset for calling, set the Web software and the IP handset as follows.

### Web software setting

1. Click [Settings] in the menu bar.
2. Click [PBX Settings] in the Settings sub menu at the left side of the screen.
3. Click [Extension] in the PBX Setting sub menu.

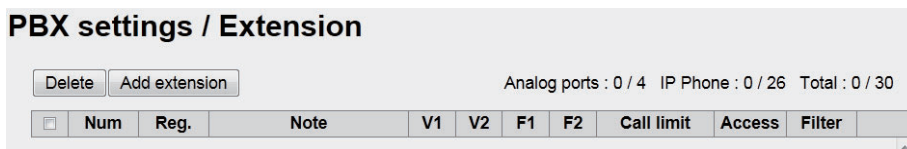

### 3. SETTING AFTER INSTALLATION

4. Click the [Add extension] button.

The following window appears. The lowest unregistered number between 1000 and 9999 appears in the [Number] box. To use this number, go to step 6. To register a different number, go to step 5.

**PBX settings / Extension / Add extension**

Number(1000-9999)	1000
Password	
Note	
Voice ring	<input checked="" type="checkbox"/> 1st (when incoming call) <input type="checkbox"/> 2nd (after 1st ring)
Fax ring	<input type="checkbox"/> 1st (when incoming call) <input type="checkbox"/> 2nd (after 1st ring)
Call limit	No limit
Access code	<input type="checkbox"/> Required
Call filter for outside call	<input type="checkbox"/> Enabled(Numbers accepted to call should be in boxes below.) _____ _____ _____ _____

To match completely, please input '#' at the end of the number.

Add Cancel

5. Key in a new extension number in the [Number] box (1000-9999).  
You cannot use a number that is already entered. If you enter the same number, an error message will appear at the registration.
6. Key in a password in the [Password] box (a maximum of eight alphanumeric characters).  
Upper case alphabet can be used.  
**Note:** Do not forget to write down the telephone number and password.
7. If necessary, enter a comment in the [Note] box (a maximum of 50 characters), for example, user name, setting location, etc.
8. Enter the outside line settings in the [Voice ring] box. (Refer to section 3.3.)
9. Enter the fax settings in the [Fax ring] box.
10. Set the transmission limit in the [Call limit] box.
  - No limit: No transmission limit.
  - Extension only: Transmission available for extension call only.
  - Incoming only: Outgoing call not available. Incoming call only.
  - Outside only: Transmission available for external call only.
11. If necessary, check [Required] in the [Access code] box to require input of access code to access an outside line. (Refer to section 3.3.)
12. In the [Call filter for outside call] box, set the restrictions for outside calling. (Refer to section 3.3.)
13. Click the [Add] button.  
The message "Completed" will appear.
14. Click the [OK] button.  
The registered number appears on the Extension screen.
15. To register multiple telephones, repeat steps 4 to 14.

**Setting in the IP handset**

1. Push the **Enter** key at the idle screen to show the main menu.

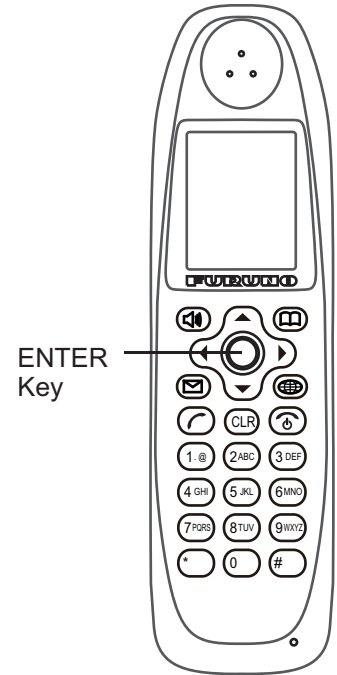
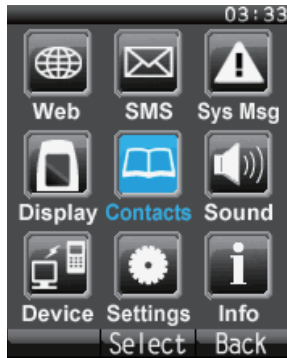

2. Push **▼** to select the Settings icon and then push the **Enter** key to show the Settings menu.

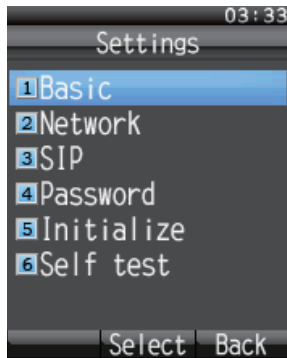

3. Push **3** key to show the SIP menu.

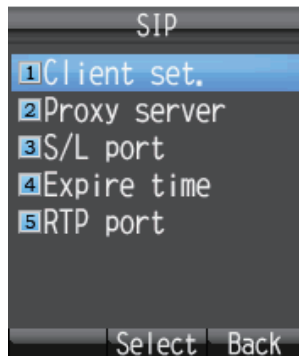

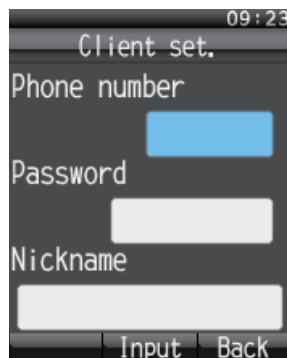

4. Push **1** key to show the Client setting screen.

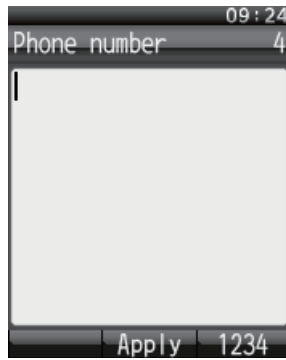

### 3. SETTING AFTER INSTALLATION

- With the Phone number box highlighted in blue, push the **Enter** key to show the phone number input screen.



- Enter the extension number that is registered in the Web software and push the **Enter** key.  
If something has been registered, push the **CLR** key to erase it.
- Push ▼ to select Password and then push the **Enter** key.
- Enter the password which was registered in the Web software and then push the **Enter** key. If the password contains both alphabet and numerals, switch input format with the soft key .

**Note:** Alphabet is the default setting of input format.

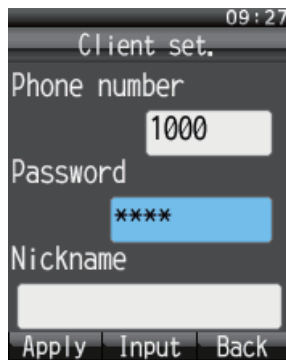

- Push the soft key  (Apply).  
The message "Set" appears and the setting for one IP handset is completed.
- Push the **CLR** key three times to return to the idle screen.
- If multiple handsets are connected, repeat the above step 1 to 10 for each handset.

When the Web software-set extension number matches handset-set extension number, the mark with a blue circle appears in the Settings/ PBX settings/ Extension window of the Web software. These handsets can be used for communication. However, the following screen does not update automatically. Press the Reload button of the browser to refresh the screen.

PBX settings / Extension											
<input type="button" value="Delete"/>		<input type="button" value="Add extension"/>		Analog ports : 1 / 4 IP Phone : 1 / 26 Total : 2 / 30							
<input type="checkbox"/>	Num	Reg.	Note	V1	V2	F1	F2	Call limit	Access	Filter	
<input type="checkbox"/>	2001	●		✓				None			<input type="button" value="Edit"/>
<input type="checkbox"/>	1000	●		✓				None			<input type="button" value="Edit"/>

*Setting Example*



## 3.9 How to Copy and Move Contacts

You can copy or move contacts between the handsets, communication unit and the SIM card. The communication unit acts as a hub for the data transfer. Administrator level (or higher) login is required to access the Contacts list menu and the Copy/Move function.

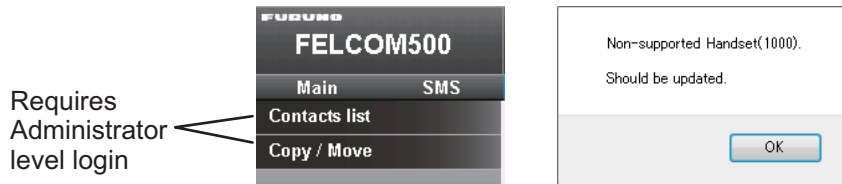

**Note:** The Copy/Move functions are only available on handsets and communication units using version 8.4 software or later. Consult your local dealer to update your software if the above-right error window is displayed when accessing the Copy/Move menu.

The Copy function creates a copy of all the source device contacts data, except short dial numbers, on the destination device.

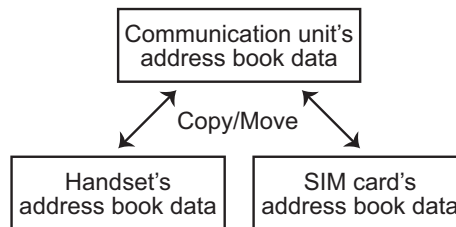

The Move function removes all contact data, except short dial numbers, from the source device and moves it to the destination device. Source data is not deleted until the move is completed.

If the copy/move is interrupted for any reason, an entry in the error log is created.

**Note:** The communication unit cannot store short dial numbers when copying/moving handset contacts to the communication unit. Therefore short dial numbers cannot be transferred between handsets.

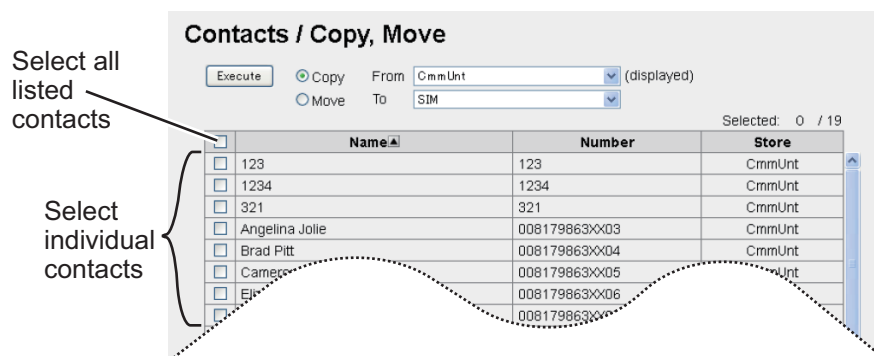

1. Click [Copy/Move] in the [Contacts] sub menu.
2. Select the source using the [From] drop-down box.
3. Select the destination using the [To] drop-down box.
4. Select contacts to be moved or copied, referring to the figure above. You can select one or more individual contacts, or select all contacts.
5. Click [Execute] to begin the copy/move process.

## 3.10 User Registration (for data connection)

Register the IP address of the handset and the PC to the user list to enable data connection from the registered handset and PC. If no IP address is entered, the standby screen of the handset shows “D: No permission”, the Web software screen shows “Data connection No permission” and data connection from unregistered handset and PC cannot be enabled.

1. Click [Settings] on the menu bar.
2. Click [Network Settings].
3. Click [WAN].
4. Click [Group Settings] to show the Network settings/WAN/Group settings screen.

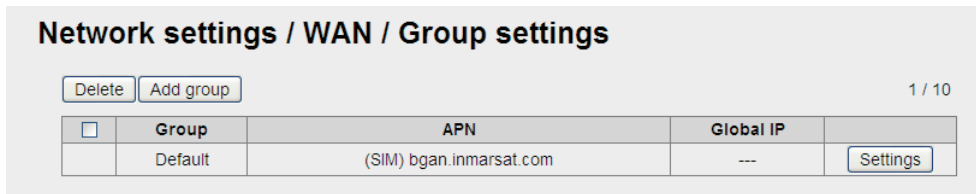

5. Click the [Settings] button to show the basic setting screen. The default setting is “standard IP packet communications service”. For SIM card and you have applied for streaming IP packet communication service, go to step 6. If you have not applied, go to step 11.

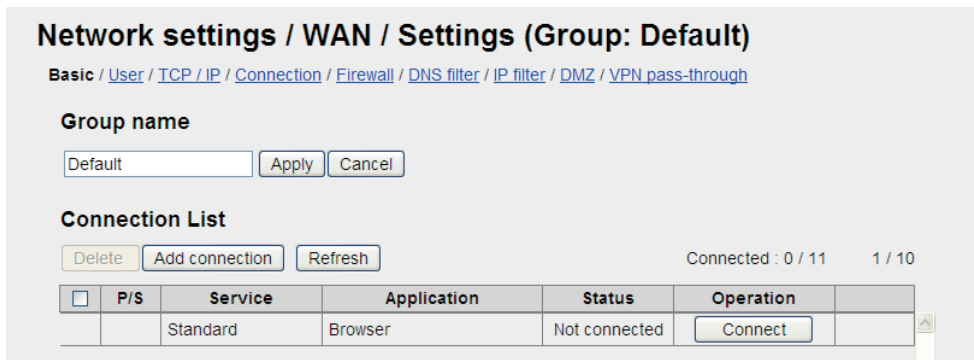

6. Click the [Add connection] button to shown the Add connection screen.

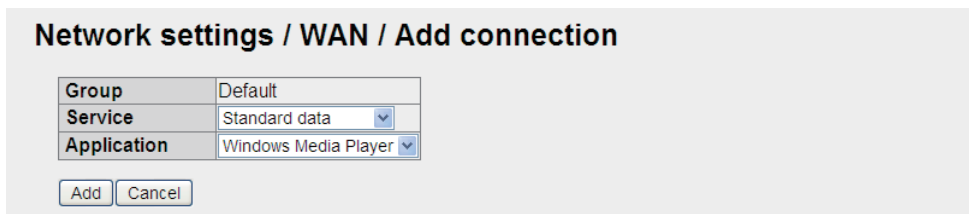

7. Enter the service to use in the [Service] box. Select one among Standard data, 8kbps Streaming, 16kbps Streaming, 32kbps Streaming, 64kbps Streaming, 128kbps Streaming, and 256kbps Streaming\*/ \* FELCOM 500 only
8. Enter the application to use in the [Application] box. Select among Windows Media Player, Quick Time, Real Player, FTP, and Browser.
9. Click the [Add] button. The message “Completed” appears.
10. Click the [OK] button to erase the message.

11. Click [User] to show the User List screen.

**Network settings / WAN / Settings (Group: Default)**

[Basic](#) / [User](#) / [TCP/IP](#) / [Connection](#) / [Firewall](#) / [DNS filter](#) / [IP filter](#) / [DMZ](#) / [VPN pass-through](#)

**User list**

Delete Add user 0 / 20

IP address

12. Click the [Add user] button to shown the Add user screen.

**Network settings / WAN / Add user**

Group Default

User  -  -  -

Add Cancel

13. Enter the IP address in the [User] box. Do not use 127.0.0.1, 255.255.255.255, or the IP address of the Communication Unit.
- Note:** If the IP addresses are the same, only one group can be registered. "192.168.1\*" and "192.168.1.10" can be registered. \* is a wildcard: show network. If you registered two groups this way, the group having the narrowest range (192.168.1.10) has priority.
14. Click the [Add] button. The message "Setting Completed." appears.
15. Click the [OK] button to erase the message.

### 3. SETTING AFTER INSTALLATION

This page is intentionally left blank.

# APPENDIX 1 JIS CABLE GUIDE

Cables listed in the manual are usually shown as Japanese Industrial Standard (JIS). Use the following guide to locate an equivalent cable locally.

JIS cable names may have up to 6 alphabetical characters, followed by a dash and a numerical value (example: DPYC-2.5).

For core types D and T, the numerical designation indicates the *cross-sectional Area (mm<sup>2</sup>)* of the core wire(s) in the cable.

For core types M and TT, the numerical designation indicates the *number of core wires* in the cable.

## 1. Core Type

D: Double core power line

T: Triple core power line

M: Multi core

TT: Twisted pair communications  
(1Q=quad cable)

## 2. Insulation Type

P: Ethylene Propylene

Rubber

## 3. Sheath Type

Y: PVC (Vinyl)

## 4. Armor Type

C: Steel

## 5. Sheath Type

Y: Anticorrosive vinyl sheath

## 6. Shielding Type

S: All cores in one sheath

-S: Individually sheathed cores

SLA: All cores in one shield, plastic tape w/aluminum tape

-SLA: Individually shielded cores, plastic tape w/aluminum tape



DPYC



TPYC

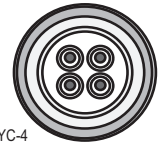

MPYC-4

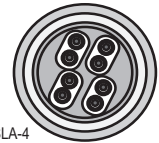

TTYCSLA-4

EX: <sup>1 2 3 4 5 6</sup> **TTYCYSLA - 4**  
 Designation type — # of twisted pairs

<sup>1 2 3 4</sup> **MPYC - 4**  
 Designation type — # of cores

The following reference table lists gives the measurements of JIS cables commonly used with Furuno products:







Type	Area	Core Diameter	Cable Diameter	Type	Area	Core Diameter	Cable Diameter
DPYC-1.5	1.5mm <sup>2</sup>	1.56mm	11.7mm	TTYCS-1	0.75mm <sup>2</sup>	1.11mm	10.1mm
DPYC-2.5	2.5mm <sup>2</sup>	2.01mm	12.8mm	TTYCS-1T	0.75mm <sup>2</sup>	1.11mm	10.6mm
DPYC-4	4.0mm <sup>2</sup>	2.55mm	13.9mm	TTYCS-1Q	0.75mm <sup>2</sup>	1.11mm	11.3mm
DPYC-6	6.0mm <sup>2</sup>	3.12mm	15.2mm	TTYCS-4	0.75mm <sup>2</sup>	1.11mm	16.3mm
DPYC-10	10.0mm <sup>2</sup>	4.05mm	17.1mm	TTYCSLA-1	0.75mm <sup>2</sup>	1.11mm	9.4mm
DPYCY-1.5	1.5mm <sup>2</sup>	1.56mm	13.7mm	TTYCSLA-1T	0.75mm <sup>2</sup>	1.11mm	10.1mm
DPYCY-2.5	2.5mm <sup>2</sup>	2.01mm	14.8mm	TTYCSLA-1Q	0.75mm <sup>2</sup>	1.11mm	10.8mm
DPYCY-4	4.0mm <sup>2</sup>	2.55mm	15.9mm	TTYCSLA-4	0.75mm <sup>2</sup>	1.11mm	15.7mm
MPYC-2	1.0mm <sup>2</sup>	1.29mm	10.0mm	TTYCY-1	0.75mm <sup>2</sup>	1.11mm	11.0mm
MPYC-4	1.0mm <sup>2</sup>	1.29mm	11.2mm	TTYCY-1T	0.75mm <sup>2</sup>	1.11mm	11.7mm
MPYCSLA-4	1.0mm <sup>2</sup>	1.29mm	11.4mm	TTYCY-1Q	0.75mm <sup>2</sup>	1.11mm	12.6mm
MPYC-7	1.0mm <sup>2</sup>	1.29mm	13.2mm	TTYCY-4	0.75mm <sup>2</sup>	1.11mm	17.7mm
MPYC-12	1.0mm <sup>2</sup>	1.29mm	16.8mm	TTYCY-4S	0.75mm <sup>2</sup>	1.11mm	21.1mm
TPYC-1.5	1.5mm <sup>2</sup>	1.56mm	12.5mm	TTYCY-4SLA	0.75mm <sup>2</sup>	1.11mm	19.5mm
TPYC-2.5	2.5mm <sup>2</sup>	2.01mm	13.5mm	TTYCYS-1	0.75mm <sup>2</sup>	1.11mm	12.1mm
TPYC-4	4.0mm <sup>2</sup>	2.55mm	14.7mm	TTYCYS-4	0.75mm <sup>2</sup>	1.11mm	18.5mm
TPYCY-1.5	1.5mm <sup>2</sup>	1.56mm	14.5mm	TTYCYSLA-1	0.75mm <sup>2</sup>	1.11mm	11.2mm
TPYCY-2.5	2.5mm <sup>2</sup>	2.01mm	15.5mm	TTYCYSLA-4	0.75mm <sup>2</sup>	1.11mm	17.9mm
TPYCY-4	4.0mm <sup>2</sup>	2.55mm	16.9mm				

# PACKING LIST

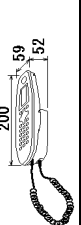
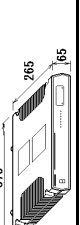
16A0-X-9852-9

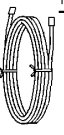



1/1

FB-2000/8000-A-J/E、-B-J/E

NAME	OUTLINE	DESCRIPTION/CODE No.	Q'TY
ユニット	UNIT		
ハンドセット IP HANDSET		FB-3000 000-015-761-00	1
通信制御ユニット COMMUNICATION UNIT		FB-2000-A/B 000-015-758-00	1
<b>通信制御用予備品 COMMUNICATION UNIT SPARE PARTS</b>			
予備品 SPARE PARTS		SP16-01901 001-067-320-00	1
<b>通信制御用工材 COMMUNICATION UNIT INSTALLATION MATERIALS CP16-03810</b>			
ケーブル(組品)LAN LAN CABLE ASSEMBLY		MO3-Z072-050- 001-167-390-10	1
ケーブル組品MJ CABLE ASSY.		MJ-AS3PF0018-050ZC 000-154-025-10	1
工事材料 INSTALLATION MATERIALS		CP16-03811 001-067-790-00	1
工事材料 INSTALLATION MATERIALS		CP16-03812 001-106-090-00	1
<b>ハンドセット工材 HANDSET INSTALLATION MATERIALS</b>			
工事材料 INSTALLATION MATERIALS		CP16-03901 001-067-350-00	1

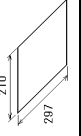
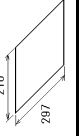
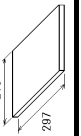
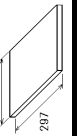
コード番号末尾の[\*\*]は、選択品の代表コードを表します。  
CODE NUMBER ENDING WITH "\*\*" INDICATES THE CODE NUMBER OF REPRESENTATIVE MATERIAL.

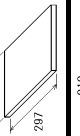
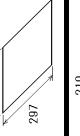
(略図の寸法は、参考値です。 DIMENSIONS IN DRAWING FOR REFERENCE ONLY.)

NAME	OUTLINE	DESCRIPTION/CODE No.	Q'TY
図書	DOCUMENT		
エリアカバーマップ SATELLITE COVERAGE AREA MAP		C52-01101-* 000-175-262-1*	1
衛星位置確認スケール SATELLITE POSITION SCALE		C52-01102-* 000-175-457-1*	1
設定事例集 EXAMPLE OF SETTING		*52-01003-* 000-174-622-1*	1
取扱説明書 OPERATOR'S MANUAL		OM*-56660-* 000-170-976-1*	1
装備要領書 INSTALLATION MANUAL		IM*-56660-* 000-170-978-1*	1
操作要領書(メガン) OPERATOR'S GUIDE (MLG)		MLG-56660-* 000-170-980-1*	1
ヒューズ変更のお願い NOTIFICATION DOCUMENT		C52-00200-* 7/L1 000-147-004-1*	1
緊急呼出シート EMERGENCY CALL SHEET		E52-00905-* 000-172-812-1*	1
型紙 PLATE		C52-00901-* 000-171-039-1*	1

型式/コード番号が2段の場合、下段より上段に代わる過渡期品であり、どちらが入っています。なお、品質は変わりません。  
TWO TYPES AND CODES MAY BE LISTED FOR AN ITEM. THE LOWER PRODUCT MAY BE SHIPPED IN PLACE OF THE UPPER PRODUCT. QUALITY IS THE SAME.

# PACKING LIST FB-1500-A/A-H/C/C-H

16A0-X-9855-7

1/1

NAME	UNIT	OUTLINE	DESCRIPTION/CODE No.	Q'TY
ユニット				
アンテナユニット			FB-1500-A/A-N/C/C-N	1
ANTENNA UNIT			000-015-744-00	**
<b>工事材料 INSTALLATION MATERIALS CP16-04401</b>				
コンベックス			CV-250B	2
CONVEX			000-171-854-10	
ビニールテープ			0.2X19X1000MMI クロ	1
VINYL TAPE			000-172-691-10	
フチルゴムテープ			NO. 15	1
SELF-BONDING TAPE			000-174-646-10	
ケミカル			S-8400W 7ルミチューブ 50G	1
SILICON RUBBER			000-158-483-11	
ゴム板			MO2219*	1
RUBBER MAT			999-999-146-00	(*)
放射警報ステッカー			L 05-10040	1
RADIATION WARNING STICKER			999-999-144-00	(*)
六角ボルト			M10X70 SUS M90-10278	4
HEX BOLT			999-999-169-00	(*)

1.(\*)は、ダミーコードに付き、注文できません。  
 (\*) THIS CODE CANNOT BE ORDERED.

2.コード番号末尾の[\*\*]は、選択品の代表コードを表します。  
 CODE NUMBER ENDING WITH "\*\*" INDICATES THE CODE NUMBER OF REPRESENTATIVE MATERIAL.

(略図の寸法は、参考値です。DIMENSIONS IN DRAWING FOR REFERENCE ONLY.)

NAME	OUTLINE	DESCRIPTION/CODE No.	Q'TY
六角ナット		M10 SUS M90-10082	8
HEX NUT		999-999-151-00	(*)
平座金		M10 SUS M90-10083	8
PLAIN WASHER		999-999-149-00	(*)
ハネ座金		M10 SUS M90-10217	8
SPRING WASHER		999-999-150-00	(*)
シールワッシャー		TWS 10X17	4
SEAL WASHER		000-159-160-10	
<b>図書 DOCUMENT</b>			
落下防止手順書		C52-00903-*	1
ANTI-DROP PROCEDURE		000-164-558-1*	

型式/コード番号が2段の場合、下段より上段に代わる過渡期品であり、どちらかが入っています。なお、品質は変わりません。  
 TWO TYPES AND CODES MAY BE LISTED FOR AN ITEM. THE LOWER PRODUCT MAY BE SHIPPED IN PLACE OF THE UPPER PRODUCT. QUALITY IS THE SAME.

# PACKING LIST FB-1250-A/A-H/C/C-H

16AR-X-9852-2

1/1

NAME	OUTLINE	DESCRIPTION/CODE No.	Q'TY
ユニット			
アンテナユニット		FB-1250-A/A-N/C/C-N	1
ANTENNA UNIT		000-019-978-00	**
工事材料	INSTALLATION MATERIALS	CP16-04502	
コンベックス		CV-250B	2
CONVEX		000-171-854-10	
ビニールテープ		0.2X19X10000MM クロ	1
VINYL TAPE		000-172-691-10	
フチルゴムテープ		NO. 15	1
SELF-BONDING TAPE		000-174-646-10	
放射警報ステッカー(小)		L5-10048	2
RADIATION WARNING STICKER		999-999-156-00	(*)
放射警報ステッカー(大)		L5-10047	1
RADIATION WARNING STICKER		999-999-157-00	(*)
ゴム板		MO2219*	1
RUBBER MAT		999-999-146-00	(*)
六角ボルト		M10X70 SUS M90-10278	4
HEX BOLT		999-999-169-00	(*)

1.コード番号末尾の[\*\*]は、選択品の代表コードを表します。

CODE NUMBER ENDING WITH "\*\*" INDICATES THE CODE NUMBER OF REPRESENTATIVE MATERIAL.

2.(\*)は、タミコードに付き、注文できません。

(\*) THIS CODE CANNOT BE ORDERED.

(略図の寸法は、参考値です。DIMENSIONS IN DRAWING FOR REFERENCE ONLY.)

NAME	OUTLINE	DESCRIPTION/CODE No.	Q'TY
平座金		M10 SUS M90-10083	8
PLAIN WASHER		999-999-149-00	(*)
ハネ座金		M10 SUS M90-10217	8
SPRING WASHER		999-999-150-00	(*)
六角ナット		M10 SUS M90-10082	8
HEX NUT		999-999-151-00	(*)
シールワッシャー		TWS 10X17	4
SEAL WASHER		000-159-160-10	
ケミシール		S-8400W アルミチューブ 50G	1
SILICON RUBBER		000-158-483-11	

型式/コード番号が2段の場合、下段より上段に代わる過渡期品であり、どちらが入っています。なお、品質は変わりません。

TWO TYPES AND CODES MAY BE LISTED FOR AN ITEM. THE LOWER PRODUCT MAY BE SHIPPED IN PLACE OF THE UPPER PRODUCT. QUALITY IS THE SAME.

THE LOWER PRODUCT MAY BE SHIPPED IN PLACE OF THE UPPER PRODUCT. QUALITY IS THE SAME.



# PACKING LIST FB-1250-B/B-H/D/D-H

16AR-X-9851-4

1/1

NAME	OUTLINE	DESCRIPTION/CODE No.	Q'TY
ユニット			
アンテナユニット		FB-1250-B/B-N/D/D-N	1
ANTENNA UNIT		000-016-488-00	**
工事材料	INSTALLATION MATERIALS	CP16-04501	
コンベックス		CV-250B	2
CONVEX		000-171-854-10	
ビニールテープ		0.2X19X10000MM クロ	1
VINYL TAPE		000-172-691-10	
フチコルクテープ		NO. 15	1
SELF-BONDING TAPE		000-174-646-10	
アース線		K02703	1
GROUND CABLE		999-999-152-00	(*)
放射警報ステッカー(大)		L5-10047	1
RADIATION WARNING STICKER		999-999-157-00	(*)
放射警報ステッカー(小)		L5-10048	2
RADIATION WARNING STICKER		999-999-156-00	(*)
ゴム板		M02716	1
RUBBER MAT		999-999-158-00	(*)

1.(\*)は、ダミーコードに付き、注文できません。

(\*) THIS CODE CANNOT BE ORDERED.

2.コード番号末尾の[\*]は、選択品の代表コードを表します。

CODE NUMBER ENDING WITH "\*" INDICATES THE CODE NUMBER OF REPRESENTATIVE MATERIAL.

(略図の寸法は、参考値です。DIMENSIONS IN DRAWING FOR REFERENCE ONLY.)

NAME	OUTLINE	DESCRIPTION/CODE No.	Q'TY
六角ナット		M6 SUS304 M90-10168	12
HEX NUT		999-999-155-00	(*)
平座金		M6 SUS304 M90-10060	6
PLAIN WASHER		999-999-153-00	(*)
ハネ座金		M6 SUS304 M90-10080	6
SPRING WASHER		999-999-154-00	(*)
ケミシール		S-8400W アルミチューブ 50G	1
SILICON RUBBER		000-158-483-11	

型式/コード番号が2段の場合、下段より上段に代わる通減期品であり、どちらかが入っています。なお、品質は変わりません。

TWO TYPES AND CODES MAY BE LISTED FOR AN ITEM. THE LOWER PRODUCT MAY BE SHIPPED IN PLACE OF THE UPPER PRODUCT. QUALITY IS THE SAME.

△

(略図の寸法は、参考値です。DIMENSIONS IN DRAWING FOR REFERENCE ONLY.)

C5667-Z01-F





CODE NO.	001-067-790-00	16A0-X-9404-4	1/1
TYPE	CP16-03811		

COMMUNICATION UNIT

FB-2000-A

**工事材料表**

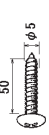
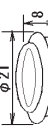
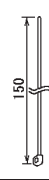
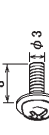
INSTALLATION MATERIALS

番号 NO.	名称 NAME	略図 OUTLINE	型名/規格 DESCRIPTIONS	数量 QTY	用途/備考 REMARKS
1	ヒューズラベル FUSE LABEL		03-153-1312-0 R0HS CODE NO. 100-292-140-10	1	
2	銅板 COPPER STRAP		05-003-0031-0 R0HS CODE NO. 590-300-310-10	1	
3	ケーブル金具 CABLE FIXTURE		16-021-2524-3 CODE NO. 100-350-365-10	1	
4	セルフタッピングネジ 1/2 SELF TAPPING SCREW		5X50 SUS304 CODE NO. 000-170-907-10	4	
5	グロメット GROMMET		C-30-SG-14A-EP-UL CODE NO. 000-173-335-10	4	
6	ケーブルタイ CABLE TIE		CY-150N CODE NO. 000-162-166-10	10	
7	バンドヘッド BINDER HEAD SCREW-F		M3X8 C2700M M6CR2 CODE NO. 000-163-536-10	3	
8	コネクタ (N) COAXIAL CONNECTOR *M TYPE*		H-P-80FB-1-GF CODE NO. 000-156-916-10	1	

(略図の寸法は、参考値です。 DIMENSIONS IN DRAWING FOR REFERENCE ONLY.)

FURUNO ELECTRIC CO., LTD.

CODE NO.	001-106-090-00	16A0-X-9412-0	1/1
TYPE	CP16-03812		

COMMUNICATION UNIT

FB-2000

**工事材料表**

INSTALLATION MATERIALS

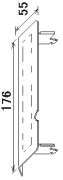
番号 NO.	名称 NAME	略図 OUTLINE	型名/規格 DESCRIPTIONS	数量 QTY	用途/備考 REMARKS
1	コネクタカバー CONNECTOR COVER		16-021-2528-0 CODE NO. 100-359-390-10	1	

型式/コード番号が2段の場合、下段より上段に代わる標準部品であり、どちらかが入っています。なお、品質は変わりません。  
TWO TYPES AND CODES MAY BE LISTED FOR AN ITEM. THE LOWER PRODUCT MAY BE SHIPPED IN PLACE OF THE UPPER PRODUCT.  
QUALITY IS THE SAME.  
(略図の寸法は、参考値です。 DIMENSIONS IN DRAWING FOR REFERENCE ONLY.)

FURUNO ELECTRIC CO., LTD.

**FURUNO**



CODE NO.	001-067-350-00	16A0-X-9405-0
TYPE	CP16-03901	1/1

IP HANDSET

FB-8000

**工事材料表**

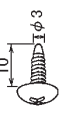
INSTALLATION MATERIALS

番号 NO.	名称 NAME	略図 OUTLINE	型名/規格 DESCRIPTIONS	数量 Q'TY	用途/備考 REMARKS
1	+self-tapping screw 1/2		3X10 SUB304 CODE NO. 000-162-604-10	4	
2	ケーブルタイ		CV-150N CODE NO. 000-162-186-10	2	

型式/コード番号が2段の場合、下段より上段に代わる通線部品であり、どちらかが入っています。なお、品質は変わりません。

TWO TYPES AND CODES MAY BE LISTED FOR AN ITEM. THE LOWER PRODUCT MAY BE SHIPPED IN PLACE OF THE UPPER PRODUCT. QUALITY IS THE SAME.

(略図の寸法は、参考値です。 DIMENSIONS IN DRAWING FOR REFERENCE ONLY.)

FURUNO ELECTRIC CO., LTD.

C5666-M05-A

**FURUNO**



CODE NO.		16A0-X-9406-0
TYPE		1/1

ANTENNA UNIT

FB-1500-A/B

**工事材料表**

INSTALLATION MATERIALS

番号 NO.	名称 NAME	略図 OUTLINE	型名/規格 DESCRIPTIONS	数量 Q'TY	用途/備考 REMARKS
1	アンテナケーブル組品		8D-FB-CV #40M* CODE NO. 000-167-889-11	1	選択 *10 BE SELECTED
2	アンテナケーブル組品		8D-FB-CV #40M* CODE NO. 000-167-890-11	1	選択 *10 BE SELECTED
3	アンテナケーブル組品		8D-FB-CV #50M* CODE NO. 000-168-241-11	1	選択 *10 BE SELECTED

型式/コード番号が2段の場合、下段より上段に代わる通線部品であり、どちらかが入っています。なお、品質は変わりません。

TWO TYPES AND CODES MAY BE LISTED FOR AN ITEM. THE LOWER PRODUCT MAY BE SHIPPED IN PLACE OF THE UPPER PRODUCT. QUALITY IS THE SAME.

(略図の寸法は、参考値です。 DIMENSIONS IN DRAWING FOR REFERENCE ONLY.)

FURUNO ELECTRIC CO., LTD.

C5666-M06-A



表 1 TABLE 1

寸法区分 (mm) DIMENSION	公差 (mm) TOLERANCE
L ≤ 50	±1.5
50 < L ≤ 100	±2.5
100 < L ≤ 500	±3
500 < L ≤ 1000	±4

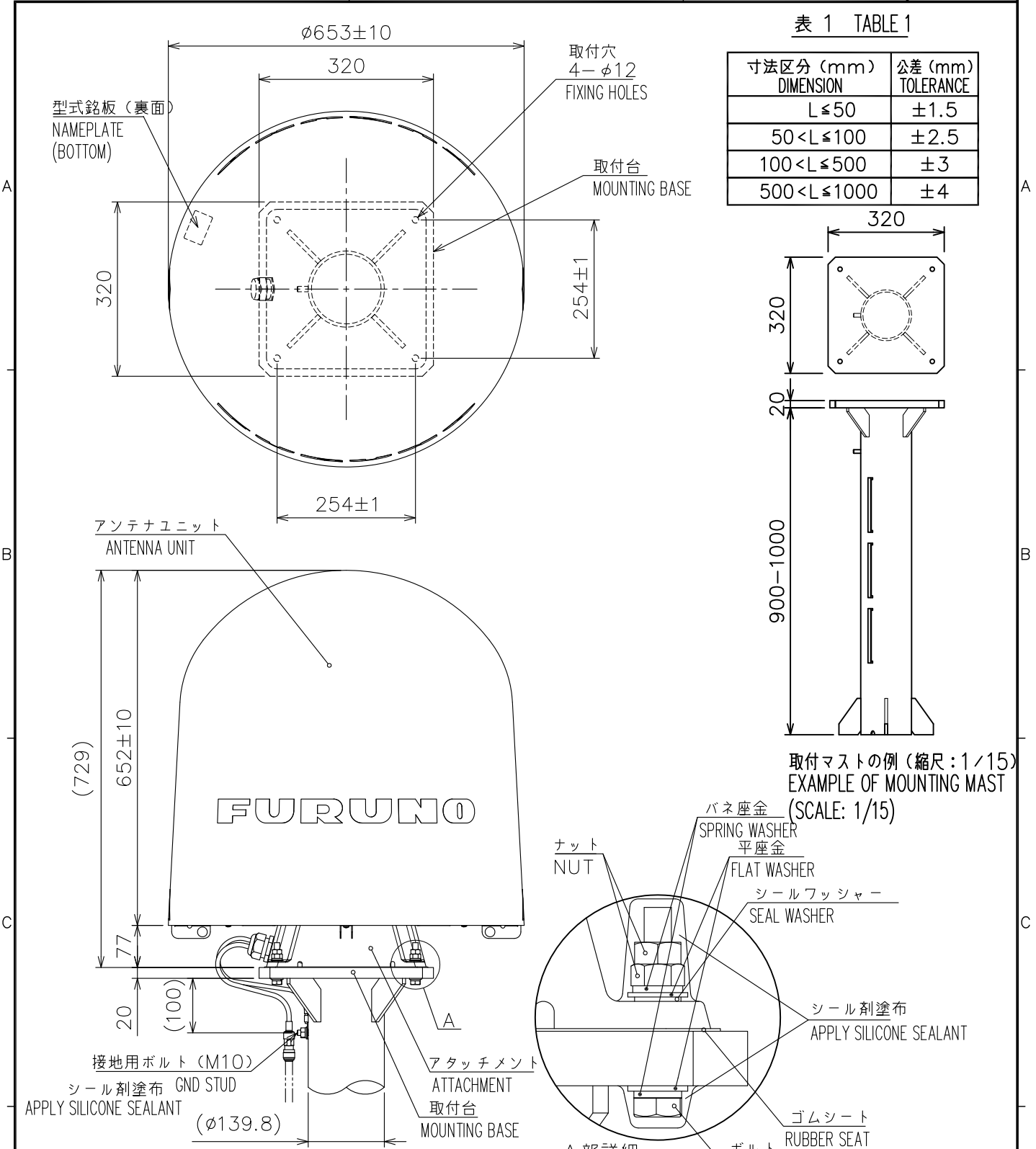

取付マスの例 (縮尺: 1/15)  
EXAMPLE OF MOUNTING MAST  
(SCALE: 1/15)

表 2 TABLE 2

型式 MODEL	質量 (kg±10%) MASS
FB-1500-A	21
FB-1500-C	22

- 注 記 1) 指定外の寸法公差は表 1 による。  
2) 取付用ネジは M10 ボルトを使用のこと。

- NOTE 1. TABLE 1 INDICATES TOLERANCE OF DIMENSIONS WHICH IS NOT SPECIFIED.  
2. USE M10 BOLTS FOR FIXING THE UNIT.

DRAWN 7/Jan/2014 I.YAMASAKI	TITLE FB-1500-A/C
CHECKED 7/Jan/2014 H.MAKI	名称 アンテナユニット (アタッチメント付)
APPROVED 7/Jan/2014 H.MAKI	外寸図
SCALE 1/10	NAME ANTENNA UNIT (W/ ATTACHMENT)
DWG. No. C5666-G03-G	REF. No. 16-021-552G-6
OUTLINE DRAWING	



表1 TABLE 1

寸法区分 (mm) DIMENSION	公差 (mm) TOLERANCE
L ≤ 50	±1.5
50 < L ≤ 100	±2.5
100 < L ≤ 500	±3

表2 TABLE 2

型式 MODEL	質量 (kg±10%) MASS
FB-1250-A	9.5
FB-1250-C	8.6

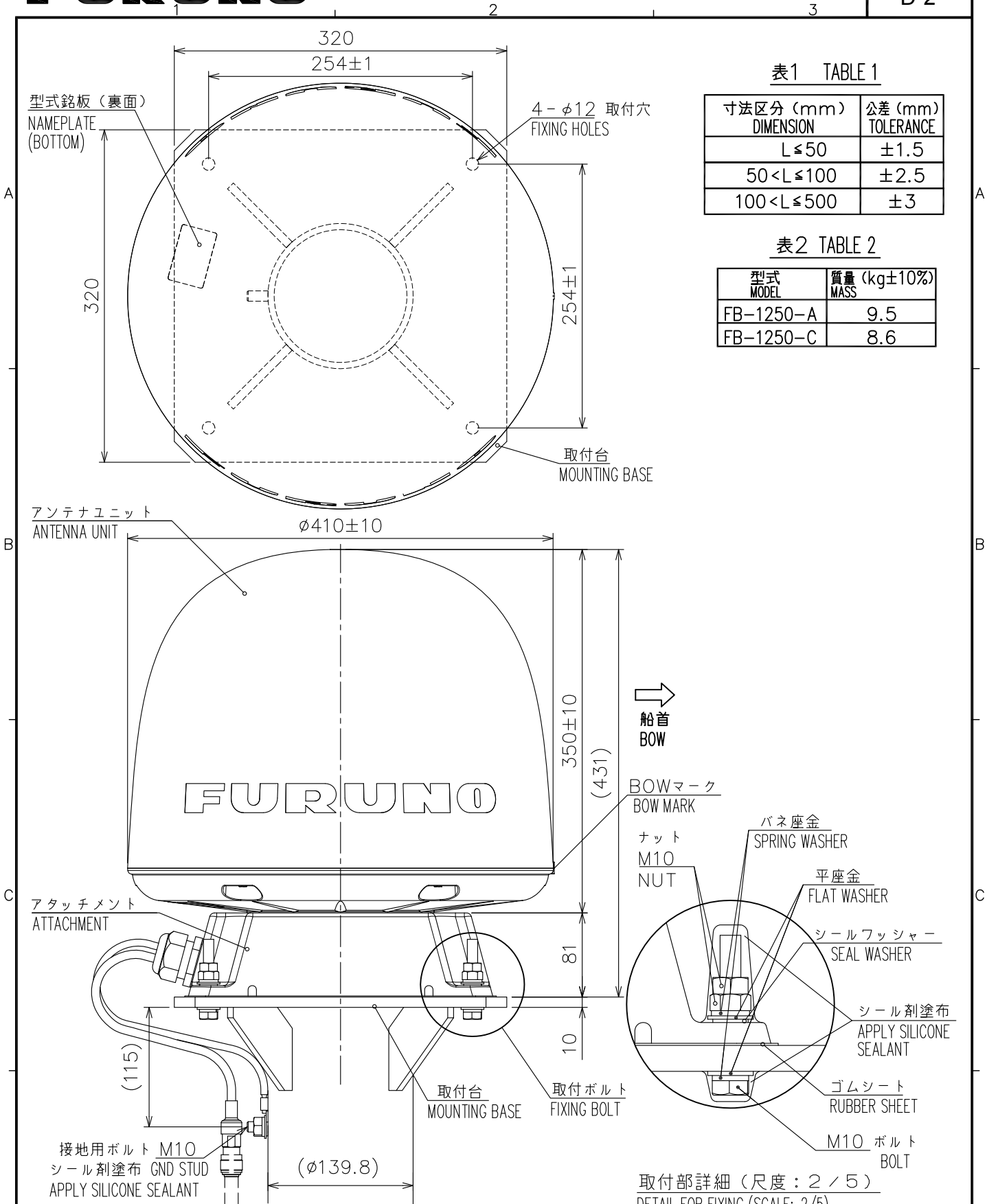
注記 1) 指定外の寸法公差は表1による。

NOTE 1. TABLE 1 INDICATES TOLERANCE OF DIMENSIONS WHICH IS NOT SPECIFIED.

取付部詳細 (尺度: 2/5)  
DETAIL FOR FIXING (SCALE: 2/5)

DRAWN 7/Jan/2014 T.YAMASAKI	TITLE FB-1250-A/C
CHECKED 7/Jan/2014 H.MAKI	名称 アンテナユニット (アタッチメント付)
APPROVED 7/Jan/2014 H.MAKI	FELCOM 250
SCALE 1/5	NAME ANTENNA UNIT (W/ ATTACHMENT)
DWG. No. C5667-G03-C	REF. No. 16-021-651G-3
OUTLINE DRAWING	

表1 TABLE 1

寸法区分 (mm) DIMENSION	公差 (mm) TOLERANCE
L ≤ 50	±1.5
50 < L ≤ 100	±2.5
100 < L ≤ 500	±3

型式銘板 (裏面)  
NAMEPLATE (BOTTOM)

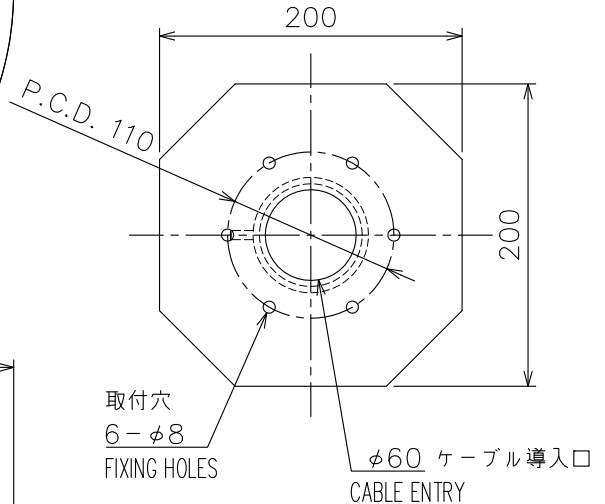
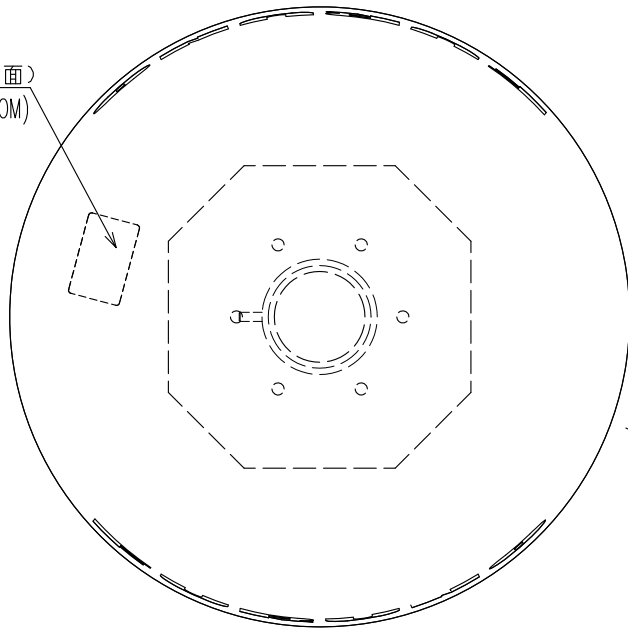

取付台寸法例  
MOUNTING BASE DIMENSIONS

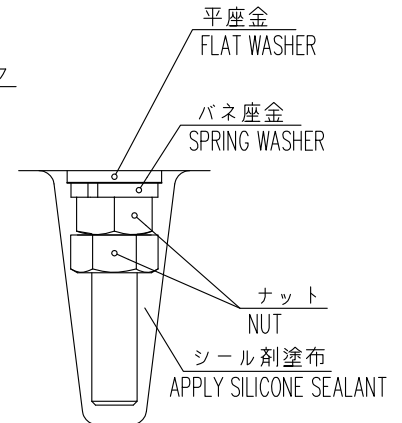
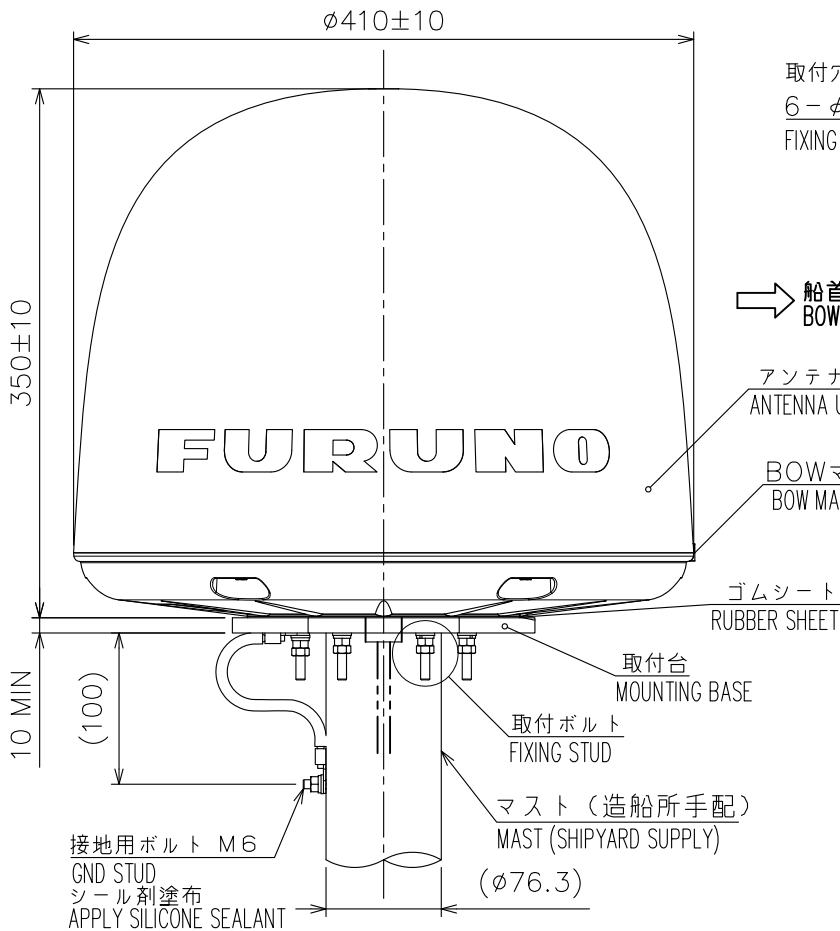

取付部詳細 (尺度: 1/1)  
DETAIL FOR FIXING (SCALE: 1/1)

表2 TABLE 2

型式 MODEL	質量 (kg±10%) MASS
FB-1250-B	6.6
FB-1250-D	5.7

注記 1) 指定外の寸法公差は表1による。  
2) ケーブルはマスト内を通る。

NOTE 1. TABLE 1 INDICATES TOLERANCE OF DIMENSIONS WHICH IS NOT SPECIFIED.  
2. ANTENNA CABLE RUNS INNER MAST.

DRAWN	7/Jan/2014 T.YAMASAKI	TITLE	FB-1250-B/D	
CHECKED	7/Jan/2014 H.MAKI	名称	アンテナユニット	
APPROVED	7/Jan/2014 H.MAKI	FELCOM 250	外寸図	
SCALE	1/5	MASS 表2参照 SEE TABLE 2	NAME	ANTENNA UNIT
DWG. No.	C5667-G01-D	REF. No.	16-021-650G-4	OUTLINE DRAWING







表1 TABLE 1

寸法区分 (mm) DIMENSION	公差 (mm) TOLERANCE
L ≤ 50	±1.5
50 < L ≤ 100	±2.5
100 < L ≤ 500	±3

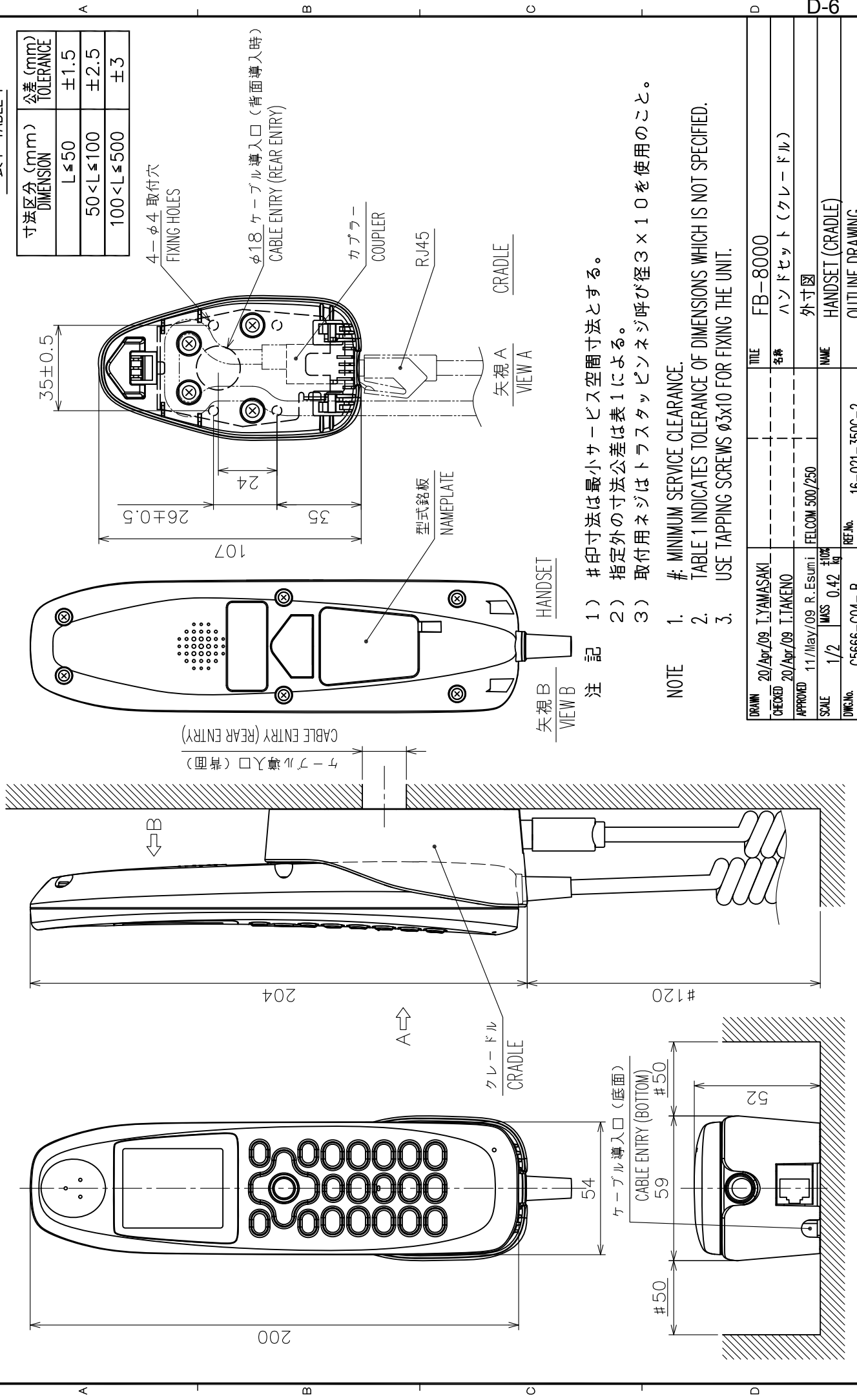

- 注記 1) #印寸法は最小サービス空間寸法とする。  
 2) 指定外の寸法公差は表1による。  
 3) 取付用ネジはトラスタップピンネジ呼び径3×10を使用のこと。

- NOTE 1. # MINIMUM SERVICE CLEARANCE.  
 2. TABLE 1 INDICATES TOLERANCE OF DIMENSIONS WHICH IS NOT SPECIFIED.  
 3. USE TAPPING SCREWS  $\phi 3 \times 10$  FOR FIXING THE UNIT.

DRAWN	20/Apr/09 I.YAMASAKI	TITLE	FB-8000
CHECKED	20/Apr/09 I.TAKENO	名称	ハンドセット (クレードル)
APPROVED	11/May/09 R.Esumi	外寸図	
SCALE	1/2	NAME	HANDSET (CRADLE)
DMC No.	C5666-G04-B	REF.No.	16-021-350G-2
			OUTLINE DRAWING

表1 TABLE 1

寸法区分 (mm) DIMENSION	公差 (mm) TOLERANCE
$L \leq 50$	$\pm 1.5$
$50 < L \leq 100$	$\pm 2.5$
$100 < L \leq 500$	$\pm 3$

A

B

C

D

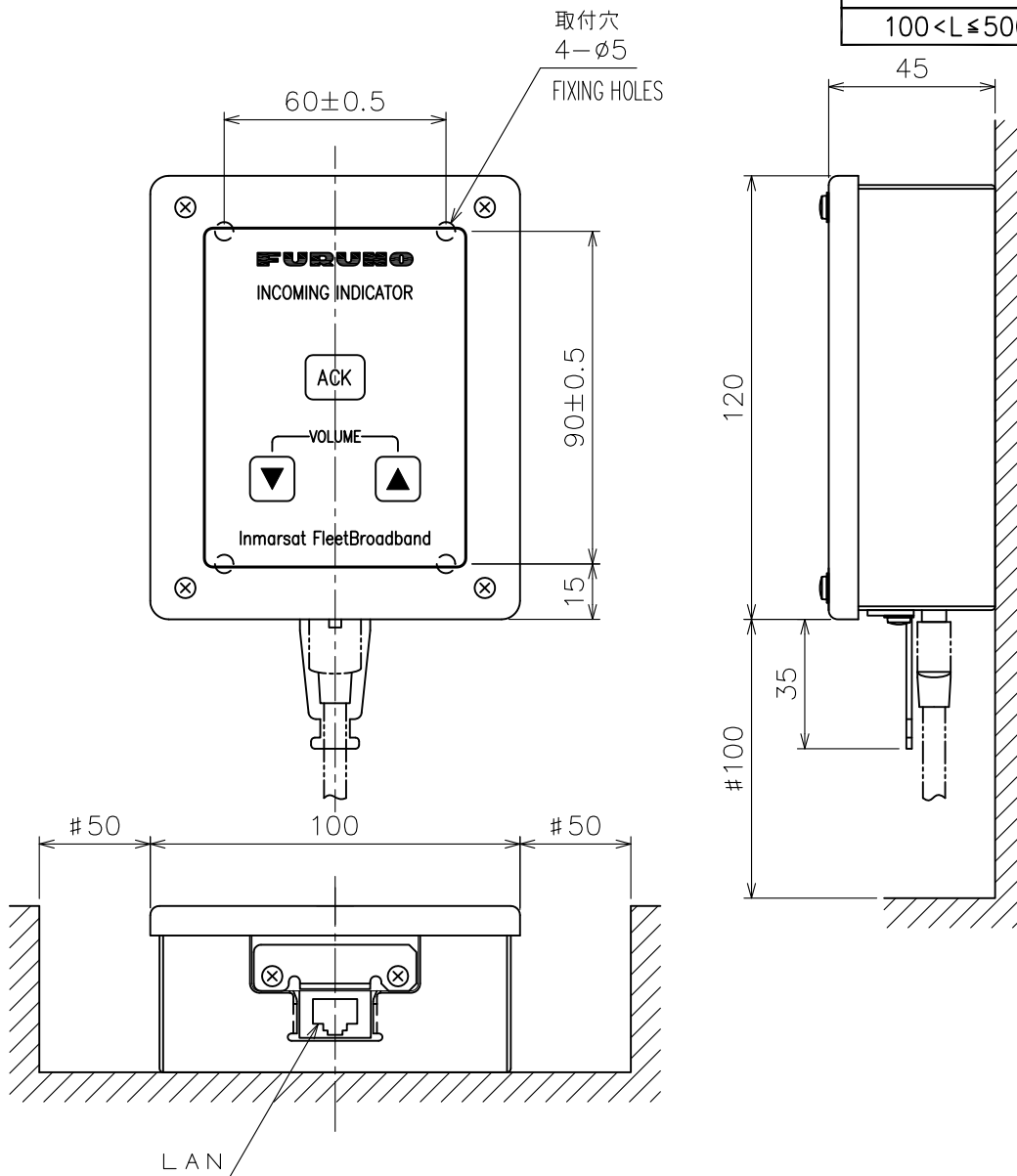

**注 記**

- 1) 指定外の寸法公差は表 1 による。
- 2) # 印寸法は最小サービス空間寸法とする。
- 3) 取付用ネジは、+ トラスタッピンネジ呼び径 4 $\times$ 16 を使用のこと。

**NOTE**

1. TABLE 1 INDICATES TOLERANCE OF DIMENSIONS WHICH IS NOT SPECIFIED.
2. #: MINIMUM SERVICE CLEARANCE.
3. USE TAPPING SCREWS  $\phi 4 \times 16$  FOR FIXING THE UNIT.

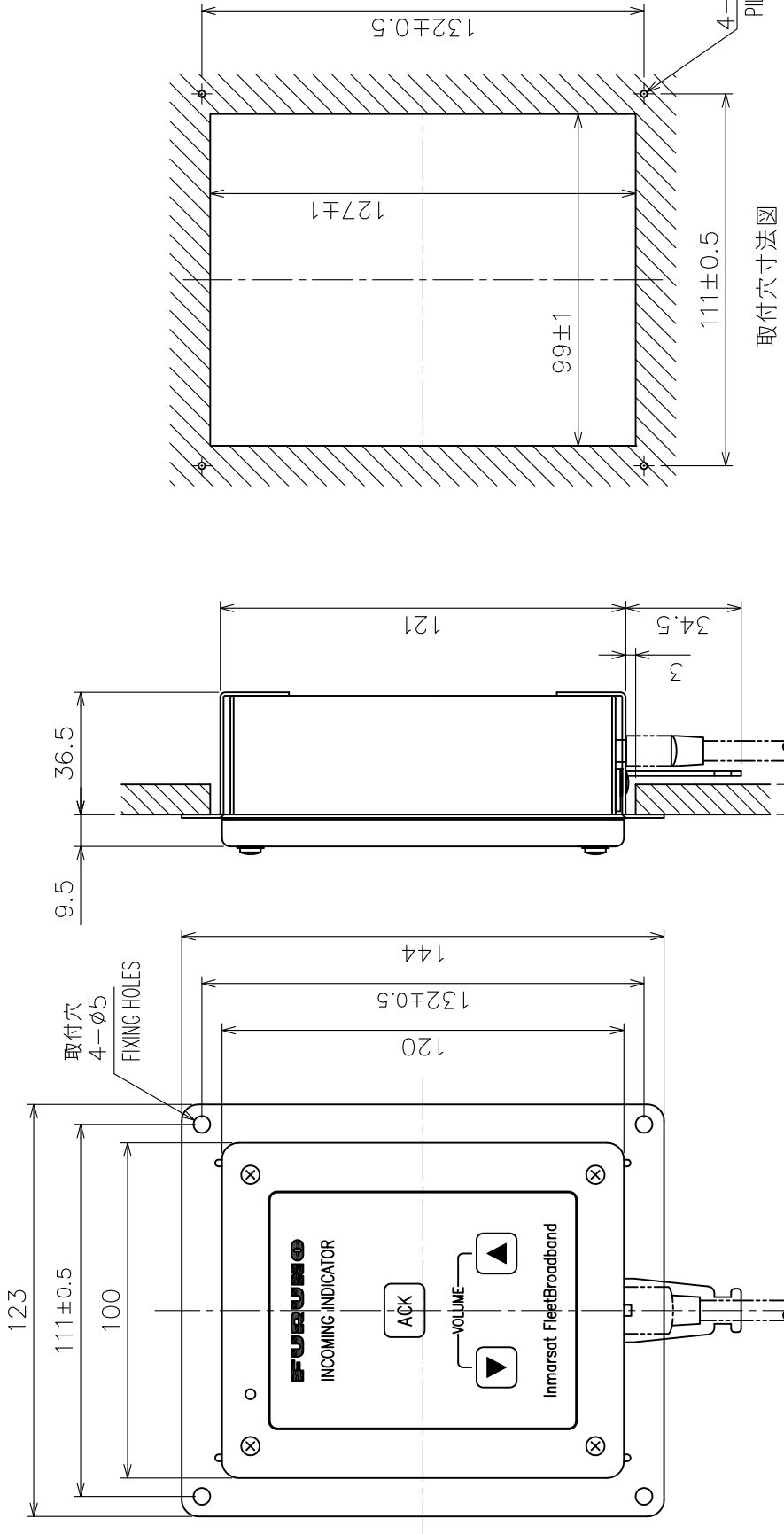
DRAWN	30/Jan/09 T.YAMASAKI		TITLE	FB-3000
CHECKED	30/Jan/09 T.TAKENO		名称	着信指示器 (壁掛装備)
APPROVED	18/Feb/09 R.Esumi	FELCOM 500/250		外寸図
SCALE	1/2	MASS 0.37 $\pm 10\%$ kg	NAME	INCOMING INDICATOR (BULKHEAD MOUNT)
DWG. No.	C5666-G05-A	REF. No.	16-021-450G-1	OUTLINE DRAWING



取付穴寸法図  
CUTOUT DIMENSIONS

表1 TABLE 1

寸法区分 (mm) DIMENSION	公差 (mm) TOLERANCE
L ≤ 50	±1.5
50 < L ≤ 100	±2.5
100 < L ≤ 500	±3

注記 1) 指定外の寸法公差は表1による。  
 2) 取付用ネジは、+トラスタックピンネジ呼び径4×16を使用のこと。  
 NOTE 1. TABLE 1 INDICATES TOLERANCE OF DIMENSIONS WHICH IS NOT SPECIFIED.  
 3. USE TAPPING SCREWS  $\phi 4 \times 16$  FOR FIXING THE UNIT.

DRAWN	30/Jan/09 I.YAMASAKI	TITLE	FB-3000
CHECKED	30/Jan/09 I.TAKENO	名称	着信指示器 (埋込装置)
APPROVED	18/Feb/09 R.Esumi	外寸図	
SCALE	1/2 MASS ±10% kg	NAME	INCOMING INDICATOR (FLUSH MOUNT)
DWG. No.	C5666-G06-A	REF. No.	16-021-451G-2
OUTLINE DRAWING			



表1 TABLE 1

寸法区分 (mm) DIMENSION	公差 (mm) TOLERANCE
$L \leq 50$	$\pm 1.5$
$50 < L \leq 100$	$\pm 2.5$
$100 < L \leq 500$	$\pm 3$

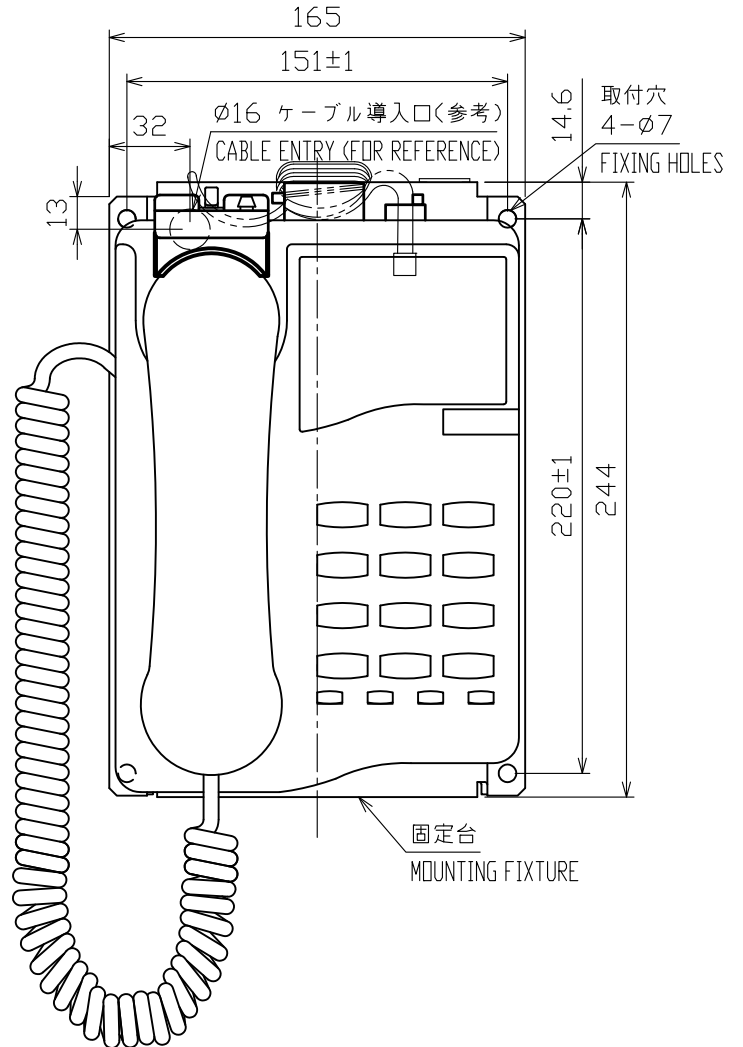
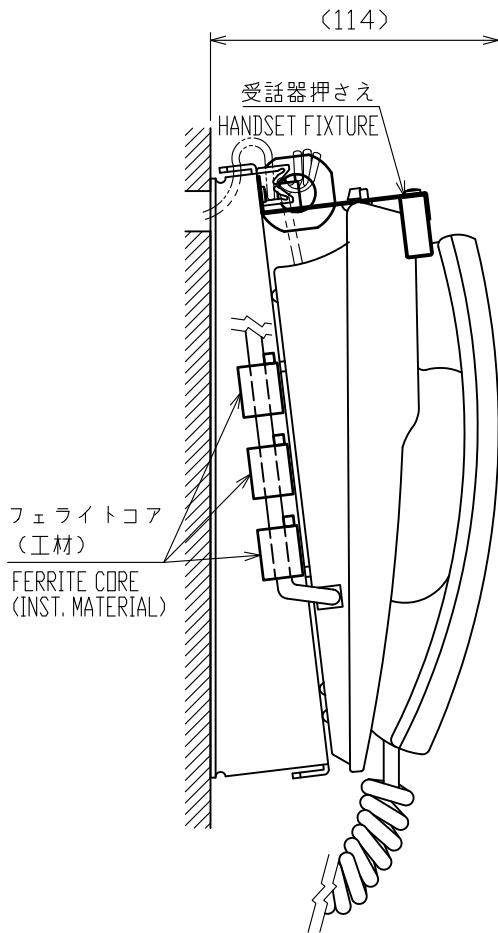
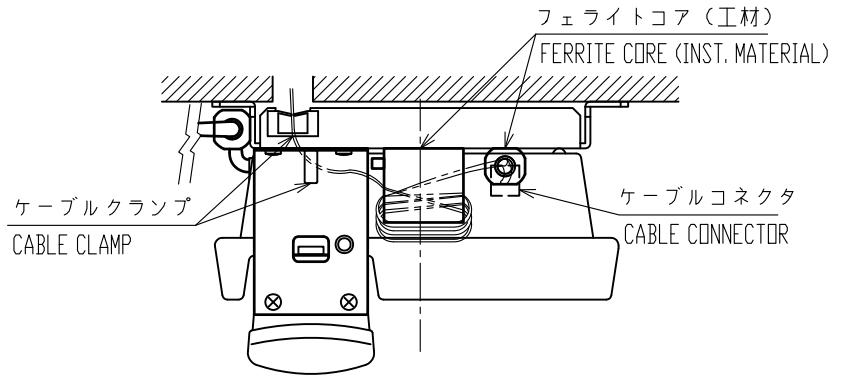

注 記

- 1) 指定外の寸法公差は表 1 による。
- 2) 取付用ネジはトラスタッピンネジ呼び径5×20を使用のこと。

NOTE

1. TABLE 1 INDICATES TOLERANCE OF DIMENSIONS WHICH IS NOT SPECIFIED.
2. USE TAPPING SCREWS  $\phi 5 \times 20$  FOR FIXING THE UNIT.

DRAWN	13/Oct/2017 T.YAMASAKI	TITLE	GEMINI 9333B4
CHECKED	13/Oct/2017 H.MAKI	名称	電話機 (傾斜型、壁掛装備)
APPROVED	16/Oct/2017 H.MAKI		外寸図
SCALE	1/3	質量 ±10% kg	質量はフェライトコアを含む。 MASS INCLUDES FERRITE CORES.
DWG. No.	C5666-G14-A	REF. No.	16-021-750G-0
			NAME TELEPHONE (w/ANGLE, BULKHEAD MOUNT)
			OUTLINE DRAWING

表1 TABLE 1

寸法区分 (mm) DIMENSION	公差 (mm) TOLERANCE
L ≤ 50	±1.5
50 < L ≤ 100	±2.5
100 < L ≤ 500	±3

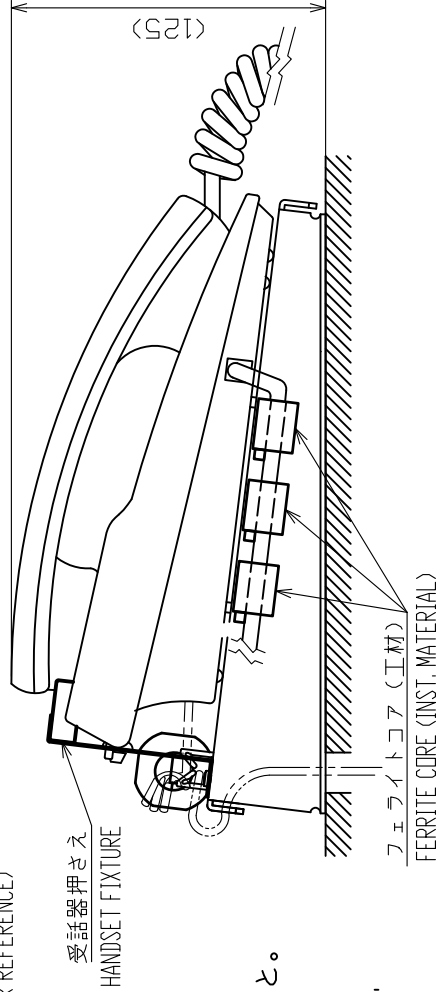
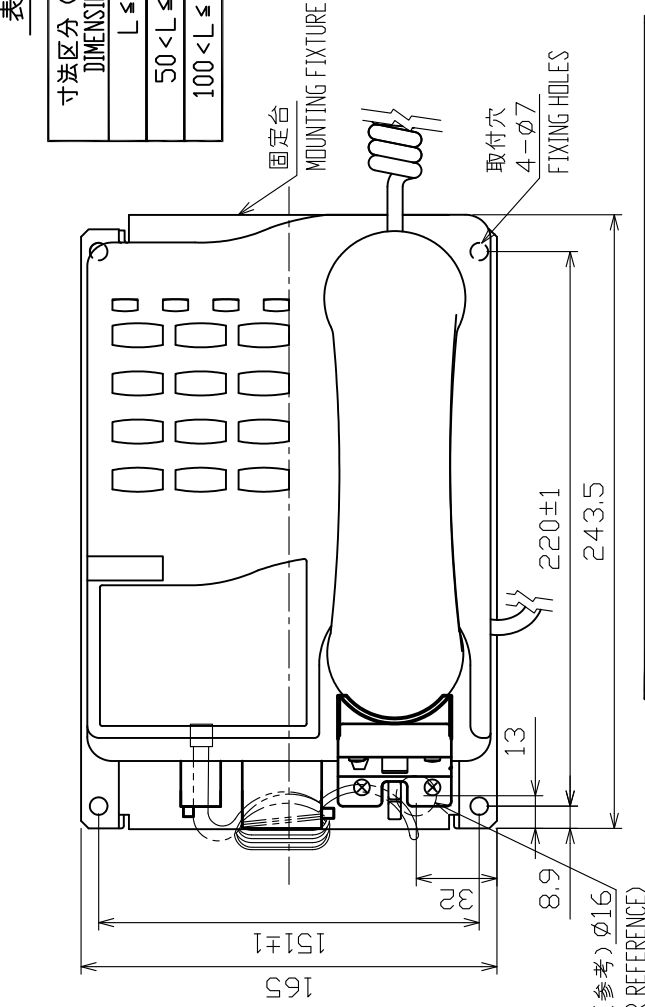

注 記

- 1) 指定外の寸法公差は表1による。
- 2) 取付用ネジはトラスタップ径5×20を使用のこと。

NOTE

1. TABLE 1 INDICATES TOLERANCE OF DIMENSIONS WHICH IS SPECIFIED.
2. USE TAPPING SCREWS Ø5x20 FOR FIXING THE UNIT.

DRAWN	13/Oct/2017 I.YAMASAKI	TITLE	GEMINI9333B4
CHECKED	13/Oct/2017 H.MAKI	名称	電話機 (傾斜型、卓上装備)
APPROVED	13/Oct/2017 H.MAKI	外寸図	
SCALE	1/3 MASS 1.1 kg	NAME	TELEPHONE (W/ANGLE, TABLETOP MOUNT)
DWG.No.	C5666-G15-A	質量はフェライトコアを含む。 MASS INCLUDES FERRITE CORES.	OUTLINE DRAWING
		REF.No.	16-021-760G-0

表1 TABLE 1

寸法区分 (mm) DIMENSION	公差 (mm) TOLERANCE
L ≤ 50	±1.5
50 < L ≤ 100	±2.5
100 < L ≤ 500	±3

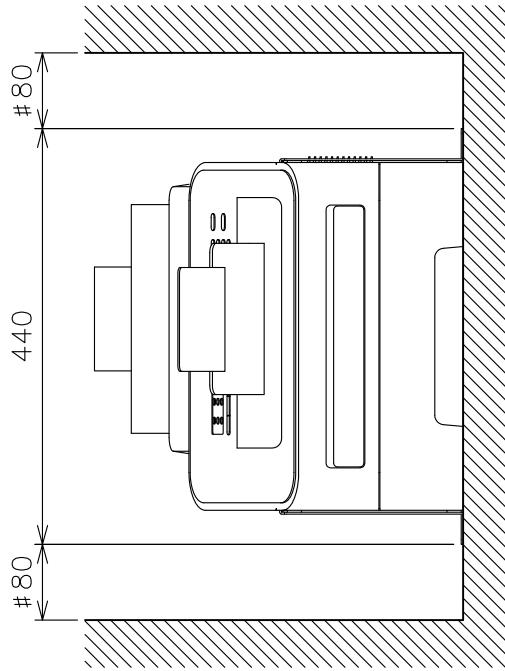
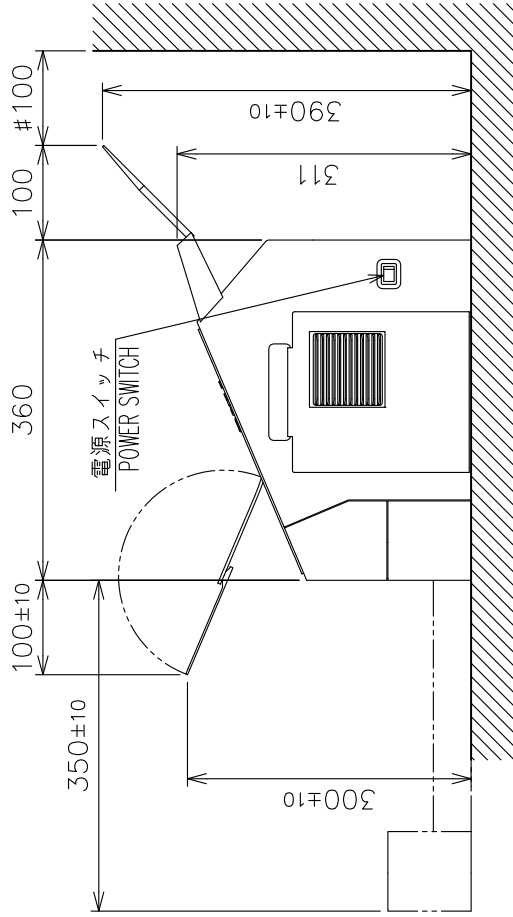
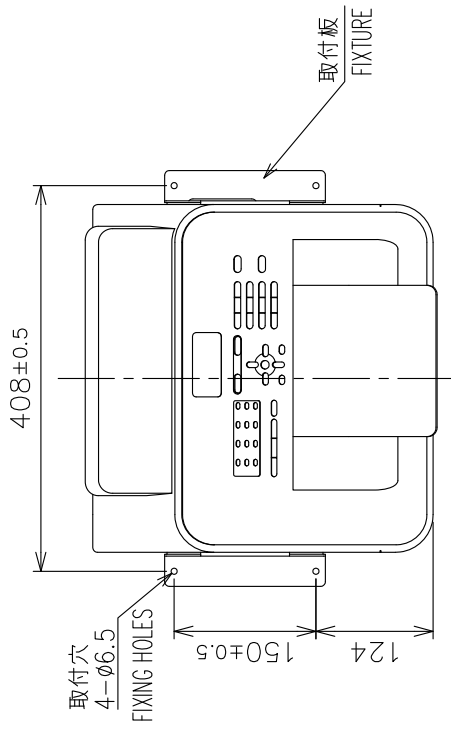

- 注記
- 1) 指定外の寸法公差は表1による。
  - 2) #印寸法は最小サービスクリアランスとする。
  - 3) 取付用ネジはトラスター呼び径5×20を使用のこと。
- NOTE
1. TABLE 1 INDICATE TOLERANCE OF DIMENSIONS WHICH IS NOT SPECIFIED.
  2. # MINIMUM SERVICE CLEARANCE.
  3. USE TAPPING SCREWS φ5x20 FOR FIXING THE UNIT.

DRAWN	5/Aug/2013	T.YAMASAKI	TITLE	FAX-2840
CHECKED	5/Aug/2013	H.MAKI	名称	ファクシミリ装置
APPROVED	5/Aug/2013	H.MAKI	外寸図	
SCALE	1/8	質量 11 kg #100 質量は取付板を含む。 MASS INCLUDES FIXTURES.	NAME	FACSIMILE MACHINE
DWG.No.	C5666-G10-A	REF.No.	16-021-455G-0	OUTLINE DRAWING



表1 TABLE 1

寸法区分 (mm) DIMENSION	公差 (mm) TOLERANCE
$L \leq 50$	$\pm 1.5$
$50 < L \leq 100$	$\pm 2.5$
$100 < L \leq 500$	$\pm 3$

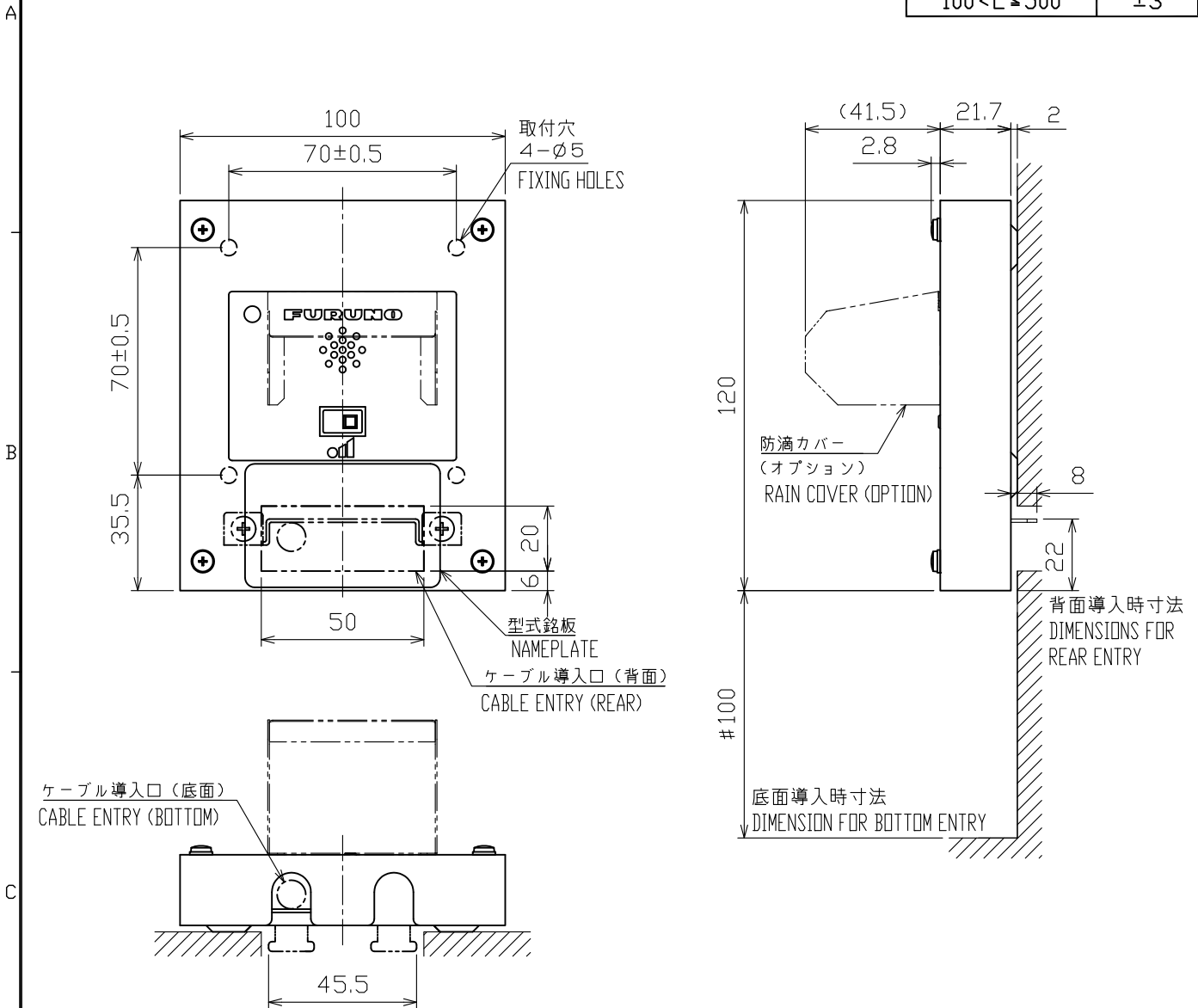

### 注 記

- 1) 指定外の寸法公差は表1による。
- 2) #印寸法は最小サービス空間寸法とする。
- 3) 取付用ネジは+タッピングネジ呼び径3×10を使用のこと。

### NOTE

1. TABLE 1 INDICATES TOLERANCE OF DIMENSIONS WHICH IS NOT SPECIFIED.
2. #: MINIMUM SERVICE CLEARANCE.
3. USE TAPPING SCREWS  $\phi 3 \times 10$  FOR FIXING THE UNIT.

DRAWN	21/Apr/2017 T.YAMASAKI	TITLE	FB-3001
CHECKED	21/Apr/2017 H.MAKI	名称	着信ベル
APPROVED	21/Apr/2017 H.MAKI		外寸図
SCALE	1/2	MASS	0.31 ±10% kg
			質量はオプションを含まず。 MASS DOES NOT INCLUDE OPTION.
DWG. No.	C5666-G13-B	REF. No.	16-025-450G-1
			NAME
			INCOMING BELL
			OUTLINE DRAWING

1

2

3

4

5

6

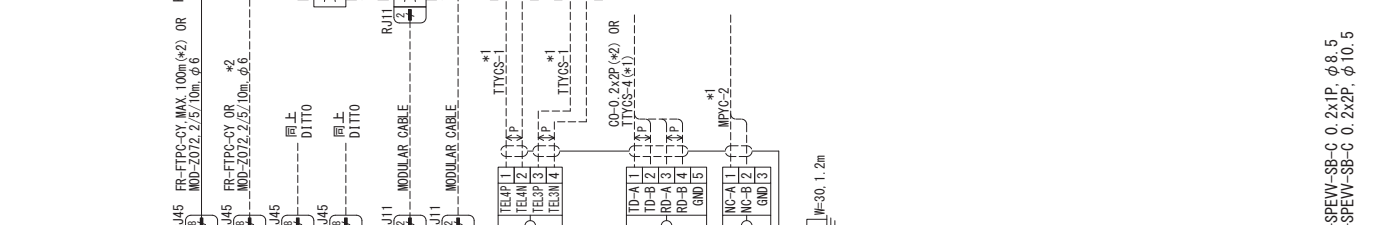
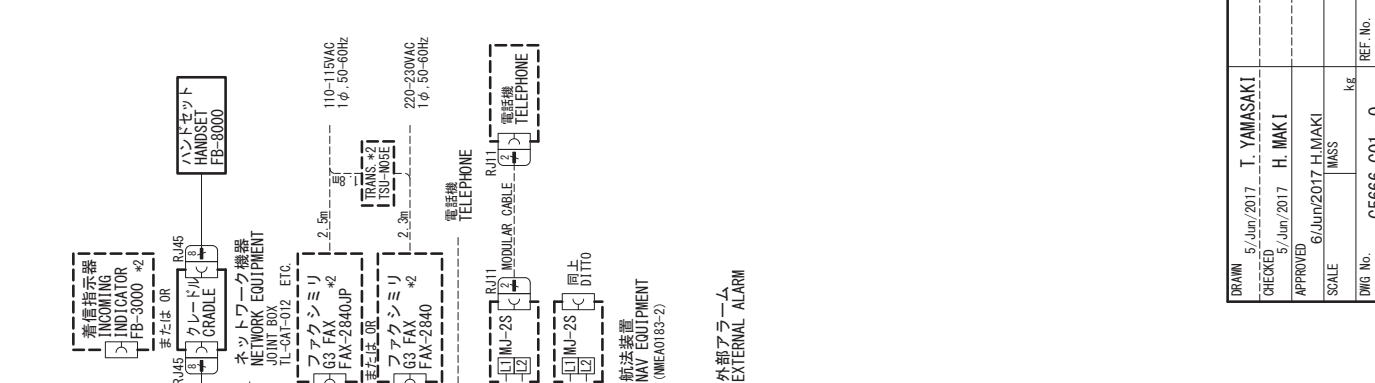
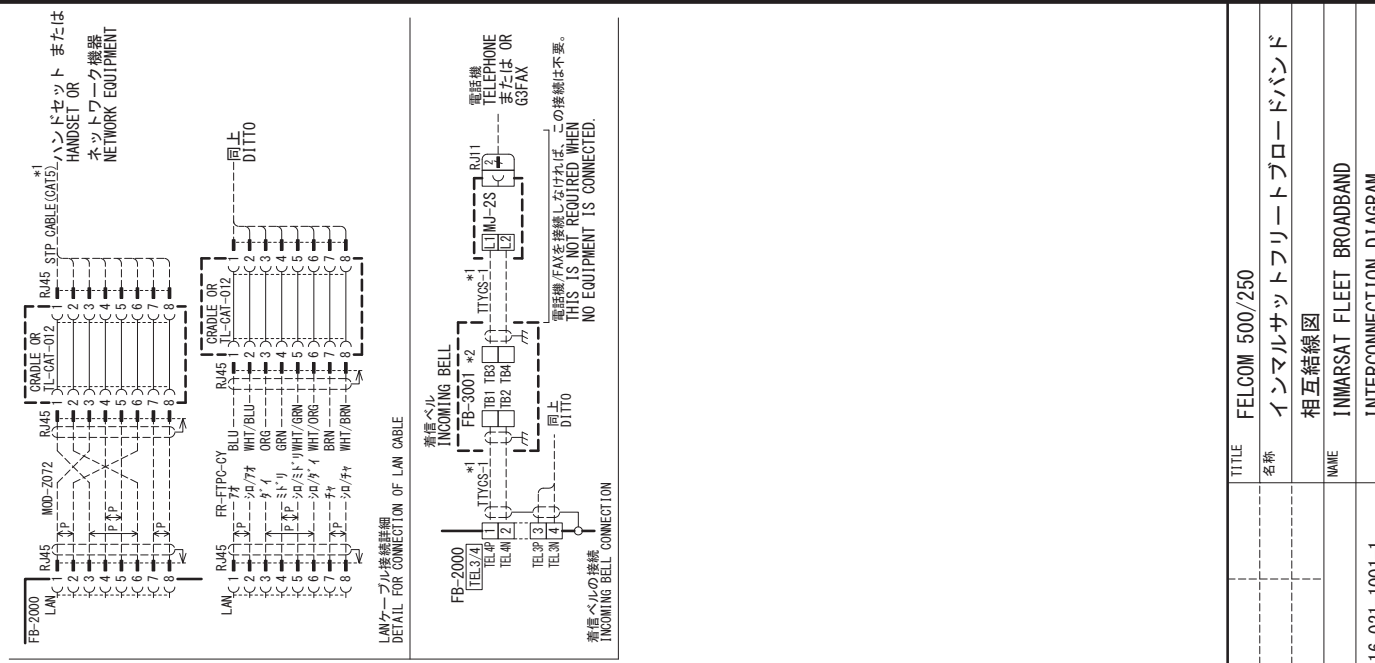

型式	アンテナユニット	備考
MODEL	ANTENNA UNIT	REMARK
500	FEELCOM FB-1500-A/C	アタッチメント付 W/ ATTACHMENT
250	FEELCOM FB-1250-A/C	アタッチメント付 W/ ATTACHMENT

-C/D: XL (L-band拡張)仕様  
-C/D: XL (Extend L-band) spec.

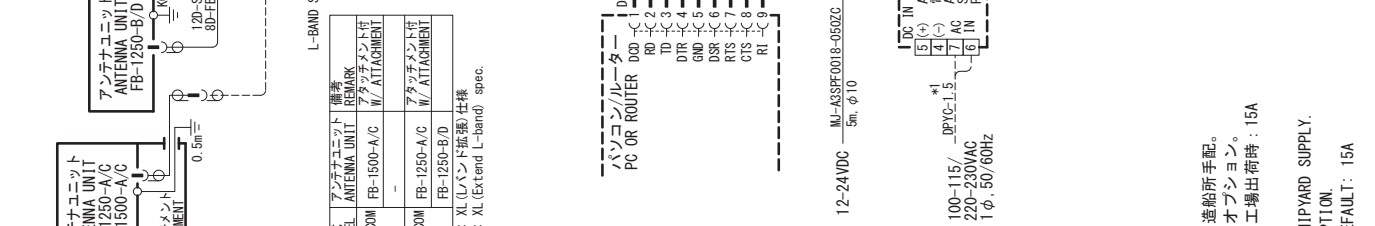
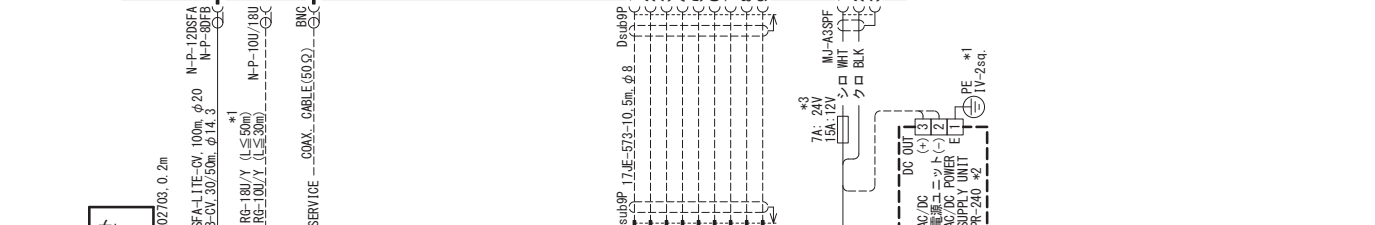

注記  
 \*1) 造船所手配。  
 \*2) オプション。  
 \*3) 工場出荷時：15A

NOTE  
 \*1: SHIPYARD SUPPLY.  
 \*2: OPTION.  
 \*3: DEFAULT: 15A